

INICIO

MÉDIA A

6ª ETAPA COPA MTC
21/10/2017 RINCAO



IMPORTANTE

DIRETOR DE PROVA
FABRICIO MEDEIROS
(CABRITO)

Nos trechos urbanos
prevalecem as leis do
codigo nacional de
transito.

É obrigação respeitar as
propriedades alheias e
os moradores.

A organização nao se
responsabiliza por
passar a programação de
navegação.

Conferir sequencias
numerica das tulipas
Onde nao a referencia
mantenha-se na
principal.

LEVANTAMENTO DA PROVA
MOTO SHERCO COM PNEU
NOVO 10 LIBRAS

BOA SORTE A
TODOS!!!!!!!!!!!!!!!!!!!!!!
!!!!!!!!!!!!



CUIDADO



ATENÇÃO



MUITA ATENÇÃO

Tempo de Prova

MÉDIA A 03:01:11



AFERIÇÃO

INICIO DA AFERIÇÃO



	0.00
	1 AFER
	0.03
	2 AFER
	0.14
	3 AFER
	0.45
	4 AFER
	0.66
	5 AFER
	1.22
	6 AFER
	1.60
	7 AFER
RETORNAR AO INICIO	
	1.84
	8 AFER



INICIO DE PROVA







INICIO DA PROVA.





	0.00	
	V 39	00.00.00
	9	T1
	0.03	
	V 39	
	10	T1
	0.14	
	V 39	
	11	T1
	0.45	
	V 39	
	12	T1
	0.66	
	V 39	
	13	T1
	1.22	
	V 39	
	14	T1
	1.60	
	V 39	
	15	T1

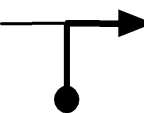
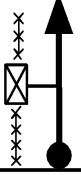
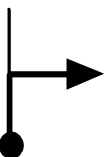



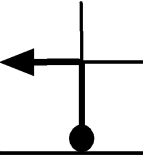
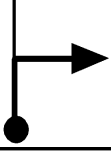

21/10/2017 RINCAO		Pág: 004	
	1.84	V 39	
	16	T1	
	2.04	V 39	
	17	T1	
	2.39	V 39	
	18	T1	
	2.66	V 45	00.04.06
	19	T2	
	3.27	V 45	
	20	T2	
	5.21	V 45	
	21	T2	
	5.46	V 45	
	22	T2	
	5.64	V 39	00.08.04
	23	T3	
	5.71	V 39	
	24	T3	

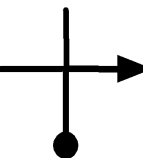
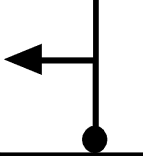
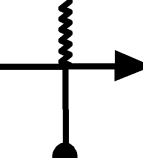
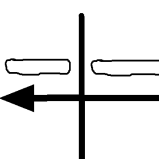
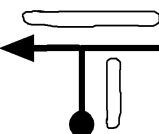



21/10/2017 RINCAO		Pág: 005	
	6.01	V 39	
	25	T3	
	6.14	V 39	
	26	T3	
	6.18	V 39	
	27	T3	
	6.53	N 2'	00.09.26
	28	T4	
	6.53	V 36	00.11.26
	29	T5	
	6.72	V 48	00.11.45
	30	T6	
	7.11	V 48	
	31	T6	
	7.23	V 48	
	32	T6	
	7.53	V 48	
	33	T6	

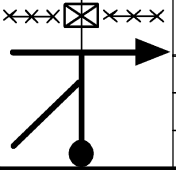
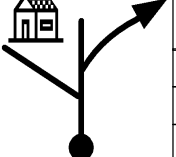
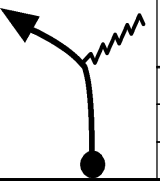



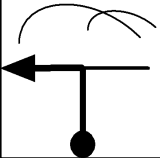

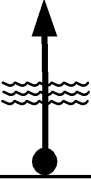
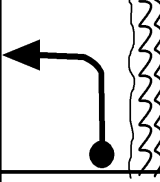

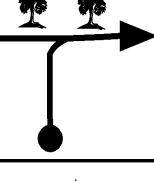
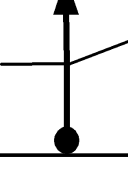
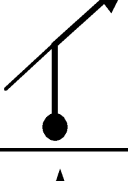
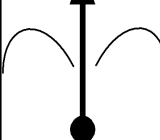
21/10/2017 RINCAO		Pág: 006	
	7.63	V 48	
	34	T6	
	8.01	V 48	
	35	T6	
	8.34	V 48	
	36	T6	
	8.36	N 1'	00.13.48
	37	T7	
	8.36	V 39	00.14.48
	38	T8	
	8.59	V 39	
	39	T8	
	8.72	V 39	
	40	T8	
	8.75	V 39	
	41	T8	
	8.98	V 39	
	42	T8	

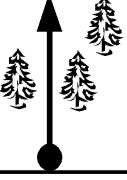

21/10/2017 RINCAO		Pág: 007	
	9.12	V 39	
		43	T8
	9.14	V 39	
		44	T8
	9.15	V 39	
		45	T8
	9.50	N 1'	00.16.33
		46	T9
	9.50		
	0.00	V 39	00.17.33
		47	T10
	0.18	V 39	
		48	T10
	0.64	V 39	
		49	T10
CAIXA DE AGUA			
	0.89	V 39	
		50	T10

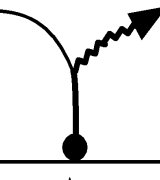

21/10/2017 RINCAO		Pág: 008	
	1.14	V 39	
		51	T10
			
	1.28	V 33	00.19.31
		52	T11
	1.41	V 33	
		53	T11
	1.55	V 33	
		54	T11
	1.84	V 36	00.20.33
		55	T12
	2.11	V 36	
		56	T12
	2.17	V 36	
		57	T12
VALO			
	2.31	V 36	
		58	T12
VALO			
	2.38	V 36	
		59	T12

21/10/2017 RINCAO		Pág: 009	
			
	2.66	V 36	
		60	T12
ATOLEIRO			
	2.74	V 36	
		61	T12
	2.79	V 36	
		62	T12
	2.93	V 33	00.22.22
		63	T13
SIGA BAMP			
	3.08	V 33	
		64	T13
	3.12	V 33	
		65	T13
	3.16	V 33	
		66	T13

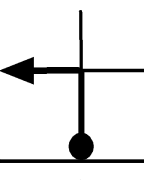
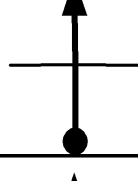
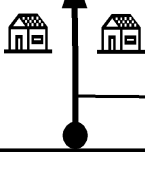
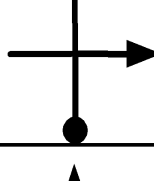
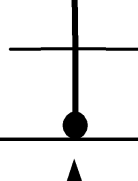
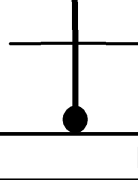
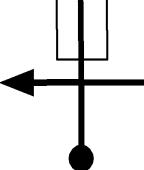

21/10/2017 RINCAO		Pág: 010	
	3.23	V 33	
		67	T13
MUITO CUIDADO			
			
	3.28	V 48	00.23.00
		68	T14
EM DIREÇÃO A CASA			
	4.00	V 42	00.23.54
		69	T15
	4.07	V 42	
		70	T15
	4.09	V 42	
		71	T15
	4.70	V 42	
		72	T15
	4.87	V 42	
		73	T15
	4.91	V 42	
		74	T15

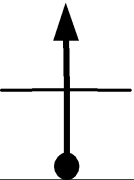

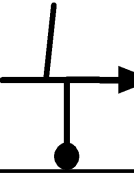
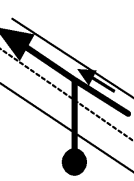
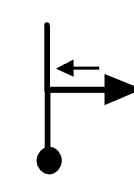

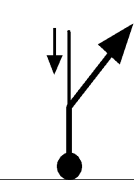
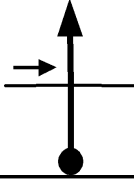
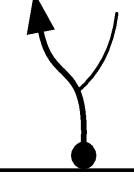
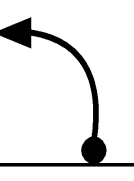
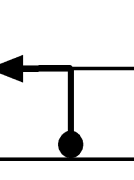
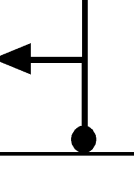
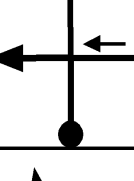
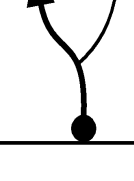
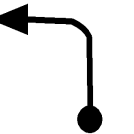

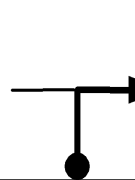
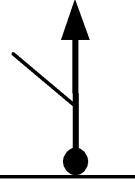
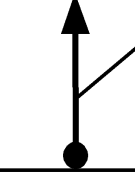
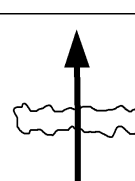
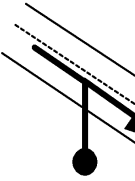
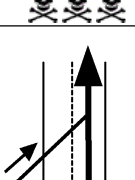
21/10/2017 RINCAO		Pág: 011	
	4.95	V 42	
		75	T15
	5.29	V 42	
		76	T15
	5.40	V 42	
		77	T15
CONTORNE A AGUA			
	5.44	V 42	
		78	T15
	5.53	V 42	
		79	T15
	5.71	N 2'	00.26.20
		80	T16
	5.71	V 39	00.28.20
		81	T17
	5.84	V 39	
		82	T17
BAMP			
	6.00	V 39	
		83	T17

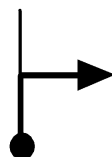

21/10/2017 RINCAO		Pág: 012	
	6.14	V 39	
		84	T17
	6.23	V 39	
		85	T17
	6.42	V 39	
		86	T17
	6.45	V 39	
		87	T17
	6.59	V 39	
		88	T17
	6.80	V 39	
		89	T17
	7.07	V 39	
		90	T17
	7.34	V 39	
		91	T17
LAJOTA			
	7.75	V 39	
		92	T17

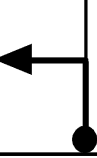
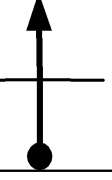

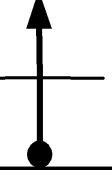

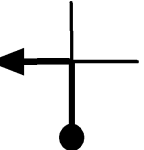
21/10/2017 RINCAO		Pág: 013	
	7.90	V 39	
		93	T17
LAGOA			
	8.33	V 39	
		94	T17
☠☠☠			
	9.23	V 39	
		95	T17
	9.95	V 39	
		96	T17
ATENÇÃO			
INICIO DESLOCAMENTO			
☠☠☠			
	11.36	D1'30s00.37.02	
		97	T18
FIM DESLOCAMENTO			
	11.50	V 27	00.38.32
	0.00	98	T19
	0.12	V 27	
		99	T19

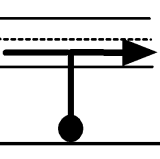
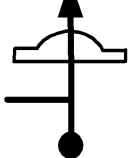
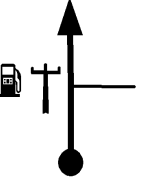
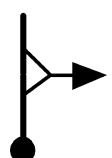
21/10/2017 RINCAO		Pág: 014	
	0.24	V 48	00.39.04
		100	T20
	0.30	V 48	
		101	T20
	0.37	V 48	
		102	T20
	0.45	V 48	
		103	T20
	0.62	V 48	
		104	T20
	0.76	V 48	
		105	T20
	0.92	V 48	
		106	T20
	0.98	V 48	
		107	T20
	1.06	V 48	
		108	T20

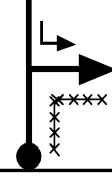
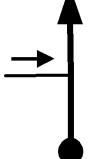
21/10/2017 RINCAO		Pág: 015	
	1.23	V 48	
		109	T20
	1.26	V 48	
		110	T20
	1.41	V 48	
		111	T20
VALO			
	1.66	V 48	
		112	T20
ATENÇÃO			
INICIO DESLOCAMENTO			
☠☠☠			
	1.96	D 2' 00.41.13	
		113	T21
☠☠☠			
	2.90	V 48	
		114	T21
ATENÇÃO			
FIM DESLOCAMENTO			
☠☠☠			
	3.04	V 39	00.43.13
		115	T22

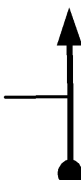
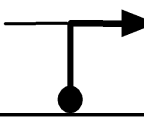
21/10/2017 RINCAO		Pág: 016	
	3.24	V 39	
		116	T22
	3.26	V 39	
		117	T22
	3.32	V 39	
		118	T22
	3.46	V 39	
		119	T22
			
	3.63	V 39	
		120	T22
	3.79	V 39	
		121	T22
	3.97	V 39	
		122	T22
	4.13	V 39	
		123	T22

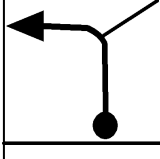
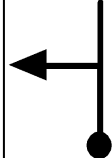

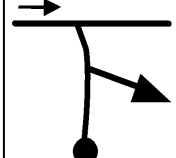
21/10/2017 RINCAO		Pág: 017	
			
	4.22	V 33	00.45.02
		124	T23
	4.36	V 33	
		125	T23
	4.92		
	0.00	V 33	00.46.18
		126	T24
	0.23	V 33	
		127	T24
FIM ASFALTO			
	0.53	V 33	
		128	T24
	1.60	N1'30s	00.49.13
		129	T25
	1.60	V 51	00.50.43
		130	T26
	2.29	V 51	
		131	T26



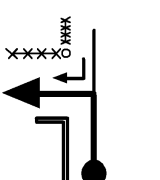
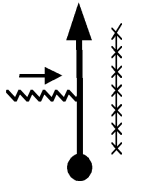
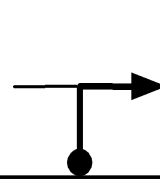
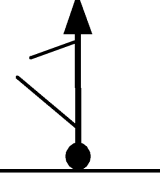
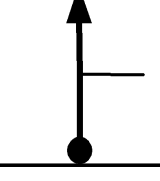

21/10/2017 RINCAO		Pág: 018	
	2.64	V 51	
		132	T26
	3.29	V 48	00.52.42
		133	T27
	3.33	V 48	
		134	T27
	3.37	V 48	
		135	T27
	3.64	V 48	
		136	T27
	3.74	V 48	
		137	T27
	3.81	V 48	
		138	T27
	3.87	V 48	
		139	T27
	4.02	V 48	
		140	T27

21/10/2017 RINCAO		Pág: 019	
	4.16	V 48	
	141	T27	
	4.25	V 48	
	142	T27	
	4.36	V 48	
	143	T27	
	4.46	V 48	
	144	T27	
	4.61	V 48	
	145	T27	
	4.63	V 48	
	146	T27	
	4.84	V 48	
	147	T27	
	5.25	V 48	
	148	T27	
	5.27	V 48	
	149	T27	

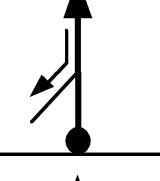
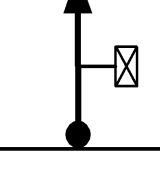
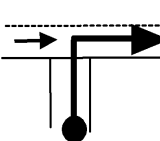

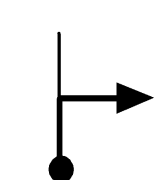
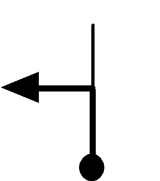
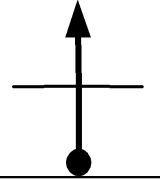

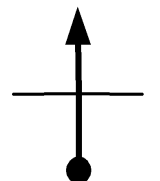
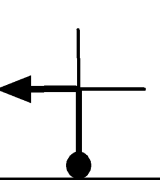
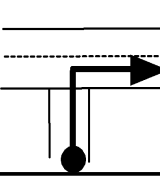
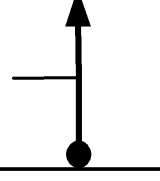

21/10/2017 RINCAO		Pág: 020	
	5.49	V 48	
	150	T27	
	5.60	V 48	
	151	T27	
	5.63	V 48	
	152	T27	
	5.85	V 48	
	153	T27	
	5.95	V 48	
	154	T27	
	6.00	V 48	
	155	T27	
	6.05	V 51	00.56.09
	156	T28	
	6.41	V 51	
	157	T28	
	7.11	V 48	00.57.24
	158	T29	

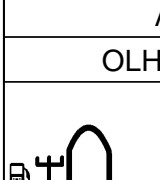
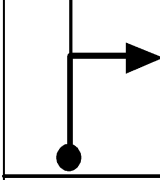
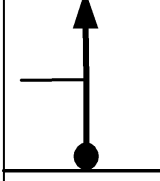
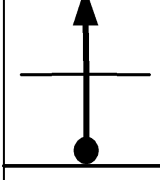
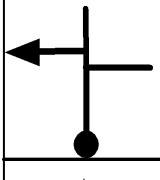
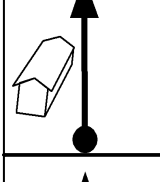
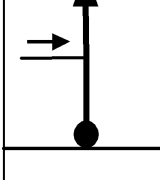
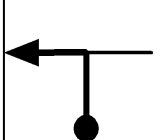

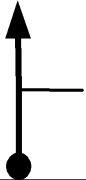

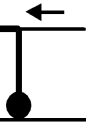
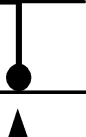
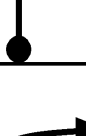

21/10/2017 RINCAO		Pág: 021	
	7.14	V 48	
	159	T29	
	7.16	V 48	
	160	T29	
	7.38	V 48	
	161	T29	
	7.45	V 48	
	162	T29	
	7.57	V 48	
	163	T29	
	8.07	V 48	
	164	T29	
	8.27	V 48	
	165	T29	
	9.04	N 4'	00.59.49
	166	T30	
	9.04	V 51	01.03.49
	167	T31	



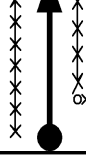

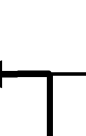
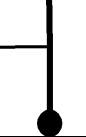

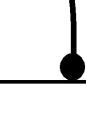
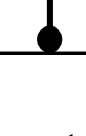
21/10/2017 RINCAO		Pág: 022	
	0.30	V 51	
		168	T31
	0.95	V 51	
		169	T31
	2.00	V 51	
		170	T31
	2.05	V 33	01.06.13
		171	T32
	2.48	V 33	
		172	T32
	2.98	N 1'	01.07.55
		173	T33
	2.98	V 27	01.08.55
		174	T34
	3.10	V 27	
		175	T34
	3.22	V 27	
		176	T34





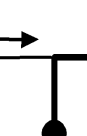

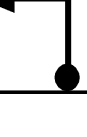
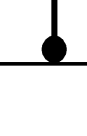
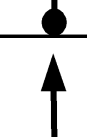
21/10/2017 RINCAO		Pág: 023	
	3.42	V 39	01.09.53
		177	T35
	3.45	V 39	
		178	T35
	3.61	V 39	
		179	T35
			
	4.10	V 39	
		180	T35
	4.26	V 39	
		181	T35
	4.30	V 27	01.11.15
		182	T36
	4.43	V 27	
		183	T36
	5.00	N 20'	01.12.48
		184	T37



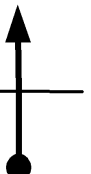
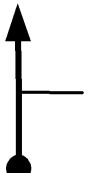

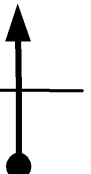



21/10/2017 RINCAO		Pág: 024	
APOIO			
OLHO DAGUA			
	5.00	V 42	01.32.48
	0.00		
		185	T38
	0.56	V 42	
		186	T38
	1.06	V 42	
		187	T38
	1.94	V 42	
		188	T38
	2.12	V 42	
		189	T38
	2.30	V 48	01.36.05
		190	T39
	2.68	V 48	
		191	T39
	3.00	V 48	
		192	T39

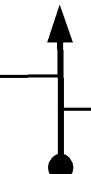







21/10/2017 RINCAO		Pág: 025	
	3.03	V 48	
	193	T39	
	3.16	V 48	
	194	T39	
	3.49	V 48	
	195	T39	
	3.66	V 48	
	196	T39	
	3.98	V 48	
	197	T39	
	4.01	V 48	
	198	T39	
	4.14	V 48	
	199	T39	
	4.44	V 45	01.38.46
	200	T40	
	4.47	V 45	
	201	T40	

21/10/2017 RINCAO		Pág: 026	
	4.50	V 39	01.38.50
	202	T41	
	5.55	V 39	
	203	T41	
	5.65	N 2'	01.40.36
	204	T42	
	5.65	V 39	01.42.36
	205	T43	
	5.72	V 39	
	206	T43	
	5.79	V 39	
	207	T43	
	6.53	V 39	
	208	T43	
	6.64	V 45	01.44.08
	209	T44	
	7.05	V 45	
	210	T44	

21/10/2017 RINCAO		Pág: 027	
	7.09	V 45	
	211	T44	
	7.15	V 45	
	212	T44	
	7.44	V 48	01.45.12
	213	T45	
	7.56	V 48	
	214	T45	
	7.89	V 48	
	215	T45	
	8.06	V 48	
	216	T45	
	8.38	V 45	01.46.22
	217	T46	
	8.40	V 45	
	218	T46	
	8.49	V 45	
	219	T46	

21/10/2017 RINCAO		Pág: 028	
	8.52	V 45	
		220	T46
	8.68	V 45	
		221	T46
	8.84	V 45	
		222	T46
	8.98	N 1'	01.47.10
		223	T47
	8.98	V 45	01.48.10
		224	T48
	9.24	V 45	
		225	T48
	9.29	V 45	
		226	T48
	9.45	V 45	
		227	T48
	9.51	V 45	
		228	T48

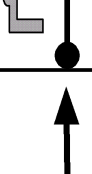
21/10/2017 RINCAO		Pág: 029	
	9.56	V 45	
		229	T48
	9.59	V 45	
		230	T48
	9.64	V 48	01.49.03
		231	T49
	9.81	V 48	
		232	T49
	10.01	V 48	
		233	T49
	10.15	V 48	01.49.41
		234	T50
	10.70	V 48	
		235	T50
	10.81	V 48	
		236	T50
	10.99	V 48	
		237	T50

21/10/2017 RINCAO		Pág: 030	
	11.07	V 48	
		238	T50
	11.13	V 48	
		239	T50
			
	11.50	N 2'	01.51.23
		240	T51
			
	11.50	0.00	V 42 01.53.23
		241	T52
	0.94	V 42	
		242	T52
	1.79	V 42	
		243	T52
	2.60	V 42	
		244	T52

21/10/2017 RINCAO		Pág: 031	
	2.97	V 42	
		245	T52
	3.11	V 42	
		246	T52
	4.25	V 42	
		247	T52
	4.38	V 42	
		248	T52
	4.75	V 42	
		249	T52
	4.87	V 42	02.00.20
		250	T53
	4.99	V 42	
		251	T53
MOTO CONTRA			
	5.14	V 42	
		252	T53
	5.23	V 42	
		253	T53

21/10/2017 RINCAO		Pág: 032	
	5.61	V 27	02.01.23
		254	T54
MOTO CONTRA			
	5.70	V 42	02.01.35
		255	T55
MOTO CONTRA			
	6.05	V 42	
		256	T55
	6.15	V 42	
		257	T55
	6.17	V 42	
		258	T55
	6.29	V 42	
		259	T55
	6.31	V 24	02.02.28
		260	T56
	6.33	V 24	
		261	T56

21/10/2017 RINCAO		Pág: 033	
	6.36	V 30	02.02.35
		262	T57
	6.40	V 30	
		263	T57
	6.51	V 39	02.02.53
		264	T58
	6.55	V 39	
		265	T58
	6.59	V 39	
		266	T58
	6.68	V 39	
		267	T58
SIGA BAMP			
	6.72	V 39	
		268	T58
	6.81	V 42	02.03.21
		269	T59
	6.94	V 42	
		270	T59

21/10/2017 RINCAO		Pág: 034	
	7.03	V 42	
	271	T59	
	7.06	V 42	
	272	T59	
	7.18	V 36	02.03.53
	273	T60	
	7.20	V 36	
	274	T60	
	7.27	V 36	
	275	T60	
	7.29	V 36	
	276	T60	
	7.34	V 36	
	277	T60	
	7.43	V 36	
	278	T60	
	7.48	V 36	
	279	T60	

21/10/2017 RINCAO		Pág: 035	
	7.50	V 24	02.04.25
	280	T61	
	7.53	V 24	
	281	T61	
	7.55	V 24	
	282	T61	
DESCE BARRANCO			
	7.56	V 30	02.04.34
	283	T62	
	7.59	V 30	
	284	T62	
	7.70	V 39	02.04.50
	285	T63	
☠☠☠			
	7.74	V 39	
	286	T63	
	7.83	V 39	
	287	T63	
	7.94	V 39	
	288	T63	

21/10/2017 RINCAO		Pág: 036	
	8.06	V 48	02.05.24
	289	T64	
	8.67	V 24	02.06.09
	290	T65	
	8.77	V 39	02.06.24
	291	T66	
☠☠☠			
	9.12	V 39	
	292	T66	
	9.21	V 39	
	293	T66	
	9.23	V 39	
	294	T66	
	9.35	V 39	
	295	T66	
	9.37	V 24	02.07.20
	296	T67	
	9.41	V 24	
	297	T67	

21/10/2017 RINCAO		Pág: 037	
	9.42	V 30	02.07.27
		298	T68
	9.46	V 30	
		299	T68
	9.57	V 39	02.07.45
		300	T69
	9.61	V 39	
		301	T69
	9.70	V 33	02.07.57
		302	T70
	9.92	V 33	
		303	T70
	9.96	V 33	
		304	T70
	10.00	V 33	
		305	T70



21/10/2017 RINCAO		Pág: 038	
	10.07	V 33	
		306	T70
	10.20	V 33	
		307	T70
	10.22	V 24	02.08.54
		308	T71
	10.24	V 24	
		309	T71
	10.26	V 30	02.09.00
		310	T72
	10.28	V 30	
		311	T72
	10.31	V 30	
		312	T72
	10.42	V 39	02.09.19
		313	T73
	10.46		
	0.00	V 39	02.09.23
		314	T74







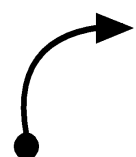
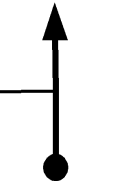
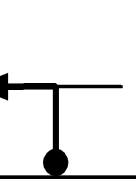
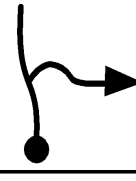
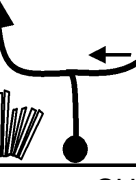

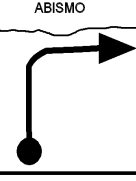
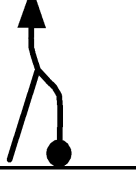
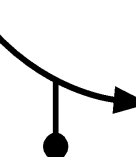
21/10/2017 RINCAO		Pág: 039	
	0.09	N 5'	02.09.31
		315	T75
	0.09	V 39	02.14.31
		316	T76
	0.68	V 42	02.15.26
		317	T77
	1.81	V 42	
		318	T77
	2.41	V 42	
		319	T77
	3.83	V 42	
		320	T77
	4.32	V 39	02.20.38
		321	T78
ATENÇÃO			
MOTO CONTRA			
	5.14	V 30	02.21.53
		322	T79

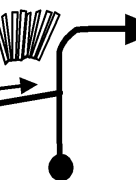

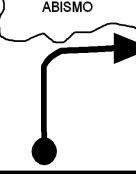
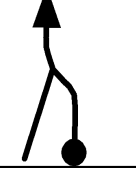
21/10/2017 RINCAO		Pág: 040	
	5.24	V 30	
		323	T79
	5.29	V 30	
		324	T79
	5.39	V 21	02.22.23
		325	T80
	5.44	V 21	
		326	T80
	5.54	V 27	02.22.49
		327	T81
MOTO CONTRA			
	5.70	V 24	02.23.10
		328	T82
	5.85	V 18	02.23.33
		329	T83
	5.94	V 18	
		330	T83
	6.00	V 18	
		331	T83

21/10/2017 RINCAO		Pág: 041	
CUIDADO!			
VALO			
	6.05	V 24	02.24.13
		332	T84
	6.09	V 24	
		333	T84
MOURÃO			
	6.15	V 24	
		334	T84
	6.29	V 18	02.24.49
		335	T85
	6.38	V 21	02.25.07
		336	T86
	6.42	V 21	
		337	T86
	7.52	V 21	
		338	T86
	7.71	V 30	02.28.55
		339	T87

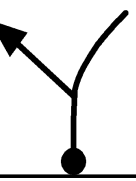
21/10/2017 RINCAO		Pág: 042	
	7.75	V 30	
		340	T87
	7.79	N 4'	02.29.05
		341	T88
	7.79	V 30	02.33.05
		342	T89
	7.94	V 30	
		343	T89
	8.03	V 30	
		344	T89
	8.08	V 39	02.33.39
		345	T90
	8.16	V 39	
		346	T90
	8.31	V 39	
		347	T90
	8.38	V 33	02.34.07
		348	T91

21/10/2017 RINCAO		Pág: 043	
	9.12	V 39	02.35.28
		349	T92
	9.20	V 39	
		350	T92
	9.46	V 39	
		351	T92
	9.60	V 33	02.36.12
		352	T93
	9.87	V 39	02.36.41
		353	T94
CUIDADO!			
ABISMO			
			
	10.06	V 39	
		354	T94
	10.09	V 39	
		355	T94
	10.40	V 39	
		356	T94

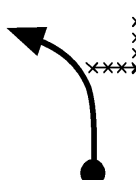
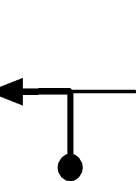

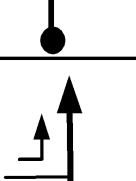
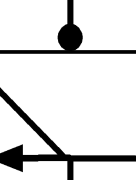
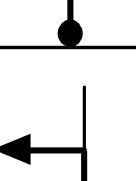
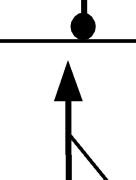
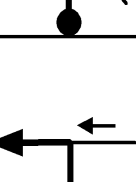
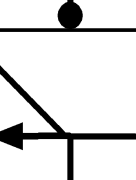

21/10/2017 RINCAO		Pág: 044	
	10.81	V 39	
		357	T94
CUIDADO!			
ABISMO			
			
	11.00	V 39	
		358	T94
	11.03	V 39	
		359	T94
			
	11.34	N 2'	02.38.57
		360	T95
	11.34	V 42	02.40.57
		361	T96
	11.36	V 42	
		362	T96
	11.50	V 42	
		363	T96

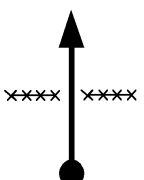

21/10/2017 RINCAO		Pág: 045	
	11.67	V 42	
		364	T96
	11.75		
	0.00	V 33	02.41.32
		365	T97
	0.22	V 15	02.41.56
		366	T98
	0.31	V 45	02.42.18
		367	T99
	0.52	V 45	
		368	T99
	0.86	V 45	
		369	T99
	0.91	V 45	
		370	T99
	1.39	V 45	
		371	T99
	1.61	V 45	
		372	T99

21/10/2017 RINCAO		Pág: 046	
	1.95	V 45	
		373	T99
	2.00	V 39	02.44.33
		374	T100
	2.06	V 39	
		375	T100
	2.23	V 39	
		376	T100
	2.26	V 39	
		377	T100
	2.72	N 3'	02.45.40
		378	T101
	2.72	V 39	02.48.40
		379	T102
	3.17	V 39	
		380	T102
	3.26	V 27	02.49.29
		381	T103

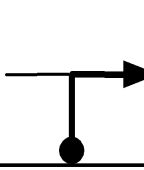
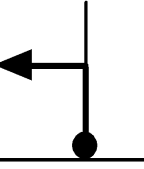
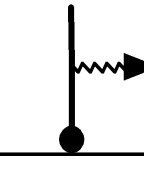
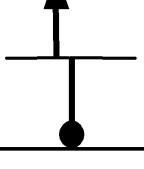
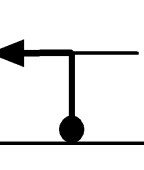
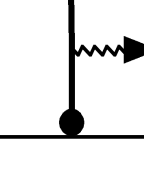
21/10/2017 RINCAO		Pág: 047	
	3.40	V 27	
		382	T103
	3.54	V 27	
		383	T103
	3.62	V 48	02.50.17
		384	T104
	4.55	V 51	02.51.27
		385	T105
	5.16	V 51	
		386	T105
	5.35	N 1'	02.52.24
		387	T106
	5.35		
	5.35	V 39	02.53.24
		388	T107
	5.47	V 39	
		389	T107
	5.60	V 39	
		390	T107

21/10/2017 RINCAO		Pág: 048	
	5.70	V 39	
		391	T107
	5.85	V 39	
		392	T107
	6.03	V 45	02.54.26
		393	T108
	6.08	V 45	
		394	T108
	6.17	V 45	
		395	T108
	6.36	V 45	
		396	T108
	6.50	V 45	
		397	T108
	6.70	V 45	
		398	T108
	6.87	V 45	
		399	T108

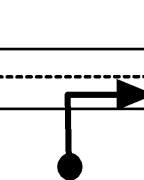
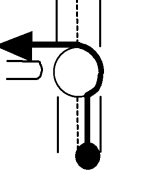
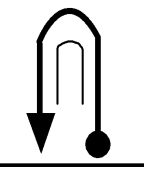
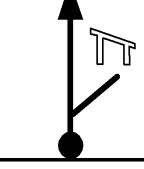
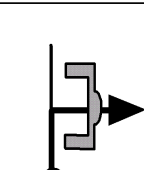
21/10/2017 RINCAO		Pág: 049	
	7.30	V 45	
		400	T108
	7.37	N1'30s02.56.14	
		401	T109
	7.37	V 36 02.57.44	
		402	T110
	7.46	V 36	
		403	T110
	7.64	V 36	
		404	T110
	7.73	V 36	
		405	T110
	7.93	V 36	
		406	T110
	7.95	V 36	
		407	T110
	8.16	N 1' 02.59.03	
		408	T111

21/10/2017 RINCAO		Pág: 050	
	8.16	V 27 03.00.03	
		409	T112
	8.30	V 27	
		410	T112
	8.54	V 27	
		411	T112
	8.64	V 27	
		412	T112
FIM DE PROVA			
	8.67	V 27 03.01.11	
		413	T112
FIM DE PROVA !!			
			
www.t15.com.br			
Obrigado pela sua participação			
Ate a proxima			
Tenha uma boa viagem de volta para sua casa!!!			
Tempo de Prova			
MÉDIA A 03:01:11			

21/10/2017 RINCAO		Pág: 051	
FIM			