

**INICIO****MÉDIA C**6ª ETAPA COPA MTC  
21/10/2017 RINCAO**IMPORTANTE**DIRETOR DE PROVA  
FABRÍCIO MEDEIROS  
(CABRITO)Nos trechos urbanos  
prevalecem as leis do  
código nacional de  
transito.É obrigação respeitar as  
propriedades alheias e  
os moradores.A organização não se  
responsabiliza por  
passar a programação de  
navegação.Conferir sequências  
numéricas das tulipasOnde não a referência  
mantenha-se na  
principal.LEVANTAMENTO DA PROVA  
MOTO SHERCO COM PNEU  
NOVO 10 LIBRASBOA SORTE A  
TODOS!!!!!!!!!!!!!!!!!!!!  
!!!!!!!!!!!!

	CUIDADO
	ATENÇÃO
	MUITA ATENÇÃO

**Tempo de Prova**

MÉDIA C 03:05:48

**AFERIÇÃO****INICIO DA AFERIÇÃO**



	0.00		
		1	<b>AFER</b>
	0.03		
		2	<b>AFER</b>
	0.14		
		3	<b>AFER</b>
	0.45		
		4	<b>AFER</b>
	0.66		
		5	<b>AFER</b>
	1.22		
		6	<b>AFER</b>
	1.60		
		7	<b>AFER</b>
RETORNAR AO INICIO			
	1.84		
		8	<b>AFER</b>



**INICIO DE PROVA**

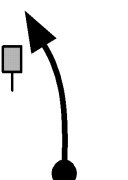
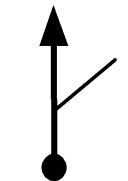
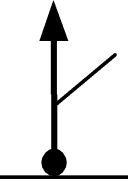
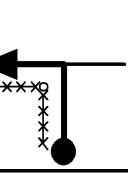
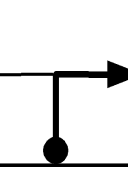
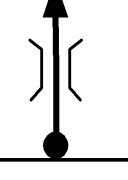
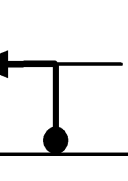
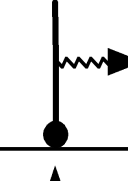
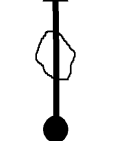

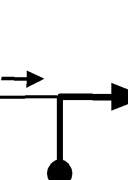
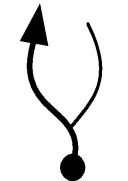

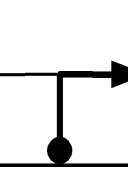
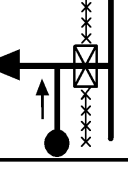
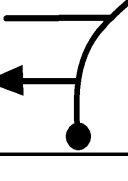
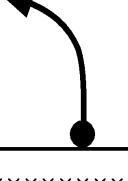
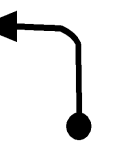

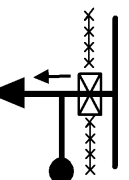
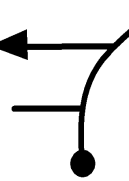
INICIO DA PROVA.

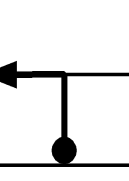
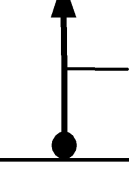
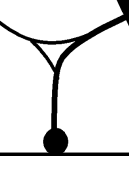
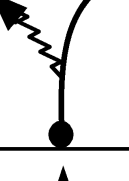
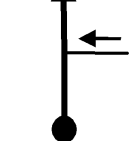

	0.00		
	V 33	00.00.00	
			9
			<b>T1</b>
	0.03		
	V 33	00.00.03	
			10
			<b>T1</b>
	0.14		
	V 33	00.00.15	
			11
			<b>T1</b>
	0.45		
	V 33	00.00.49	
			12
			<b>T1</b>
	0.66		
	V 33	00.01.12	
			13
			<b>T1</b>
	1.22		
	V 33	00.02.13	
			14
			<b>T1</b>
	1.60		
	V 33	00.02.55	
			15
			<b>T1</b>

21/10/2017 RINCAO		Pág: 004	
	1.84	V 33	00.03.21
	16	<b>T1</b>	
	2.04	V 33	00.03.43
	17	<b>T1</b>	
	2.39	V 33	00.04.21
	18	<b>T1</b>	
	2.66	V 39	00.04.50
	19	<b>T2</b>	
	3.27	V 39	00.05.46
	20	<b>T2</b>	
	5.21	V 39	00.08.46
	21	<b>T2</b>	
	5.46	V 39	00.09.09
	22	<b>T2</b>	
	5.64	V 33	00.09.25
	23	<b>T3</b>	
	5.71	V 33	00.09.33
	24	<b>T3</b>	

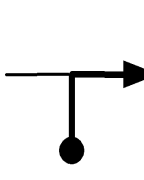

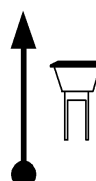
21/10/2017 RINCAO		Pág: 005	
	6.01	V 33	00.10.06
	25	<b>T3</b>	
	6.14	V 33	00.10.20
	26	<b>T3</b>	
	6.18	V 33	00.10.24
	27	<b>T3</b>	
	6.53	N 1'	00.11.02
	28	<b>T4</b>	
	6.53	V 30	00.12.02
	29	<b>T5</b>	
	6.72	V 42	00.12.25
	30	<b>T6</b>	
	7.11	V 42	00.12.59
	31	<b>T6</b>	
	7.23	V 42	00.13.09
	32	<b>T6</b>	
	7.53	V 42	00.13.35
	33	<b>T6</b>	

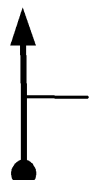

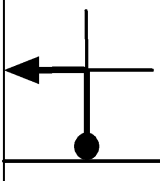
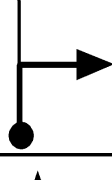
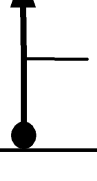
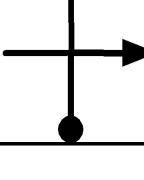
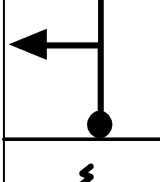
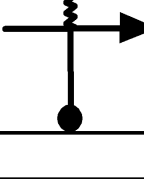
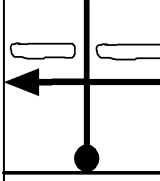
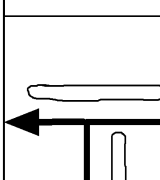

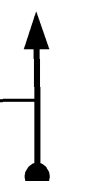
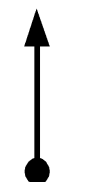
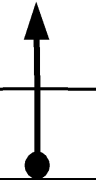
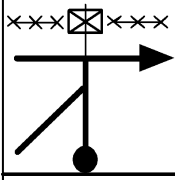
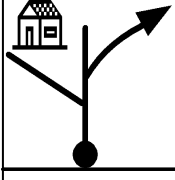
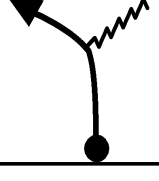
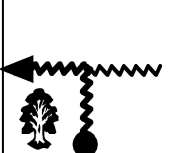

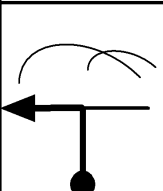
21/10/2017 RINCAO		Pág: 006	
	7.63	V 42	00.13.43
	34	<b>T6</b>	
	8.01	V 42	00.14.16
	35	<b>T6</b>	
	8.34	V 42	00.14.44
	36	<b>T6</b>	
	8.36	N 1'	00.14.46
	37	<b>T7</b>	
	8.36	V 33	00.15.46
	38	<b>T8</b>	
	8.59	V 33	00.16.11
	39	<b>T8</b>	
	8.72	V 33	00.16.25
	40	<b>T8</b>	
	8.75	V 33	00.16.28
	41	<b>T8</b>	
	8.98	V 33	00.16.53
	42	<b>T8</b>	

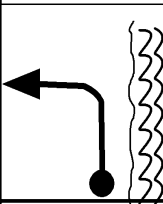
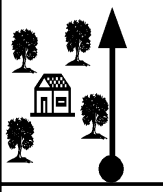
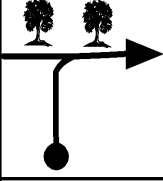
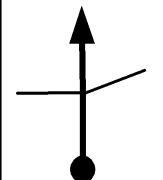
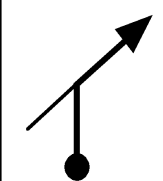
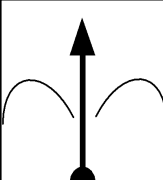

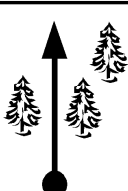
21/10/2017 RINCAO		Pág: 007	
	9.12	V 33	00.17.09
		43	T8
	9.14	V 33	00.17.11
		44	T8
	9.15	V 33	00.17.12
		45	T8
	9.50	N 1'	00.17.50
		46	T9
	9.50		
	0.00	V 33	00.18.50
		47	T10
	0.18	V 33	00.19.10
		48	T10
	0.64	V 33	00.20.00
		49	T10
CAIXA DE AGUA			
	0.89	V 33	00.20.27
		50	T10

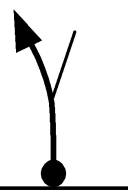
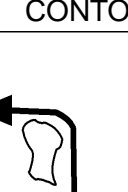

21/10/2017 RINCAO		Pág: 008	
	1.14	V 33	00.20.54
		51	T10
			
	1.28	V 33	00.21.10
		52	T11
	1.41	V 33	00.21.24
		53	T11
	1.55	V 33	00.21.39
		54	T11
	1.84	V 30	00.22.11
		55	T12
	2.11	V 30	00.22.43
		56	T12
	2.17	V 30	00.22.50
		57	T12
VALO			
	2.31	V 30	00.23.07
		58	T12
VALO			
	2.38	V 30	00.23.16
		59	T12

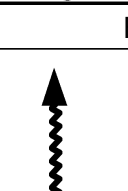
21/10/2017 RINCAO		Pág: 009	
			
	2.66	V 30	00.23.49
		60	T12
ATOLEIRO			
	2.74	V 30	00.23.59
		61	T12
	2.79	V 30	00.24.05
		62	T12
	2.93	V 27	00.24.22
		63	T13
SIGA BAMP			
	3.08	V 27	00.24.42
		64	T13
	3.12	V 27	00.24.47
		65	T13
	3.16	V 27	00.24.52
		66	T13

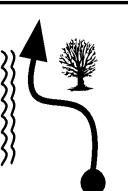
21/10/2017 RINCAO		Pág: 010	
	<b>3.23</b>	V 27	00.25.02
		67	<b>T13</b>
MUITO CUIDADO			
			
	<b>3.28</b>	V 42	00.25.08
		68	<b>T14</b>
EM DIREÇÃO A CASA			
	<b>4.00</b>	V 36	00.26.10
		69	<b>T15</b>
	<b>4.07</b>	V 36	00.26.17
		70	<b>T15</b>
	<b>4.09</b>	V 36	00.26.19
		71	<b>T15</b>
	<b>4.70</b>	V 36	00.27.20
		72	<b>T15</b>
	<b>4.87</b>	V 36	00.27.37
		73	<b>T15</b>
	<b>4.91</b>	V 36	00.27.41
		74	<b>T15</b>

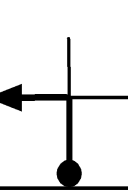
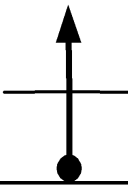
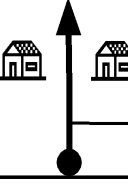
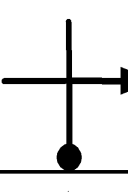
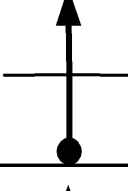
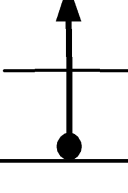
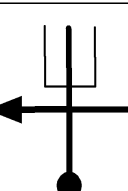

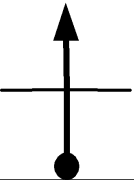

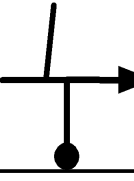
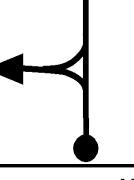
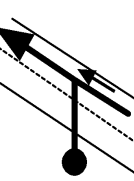
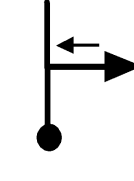
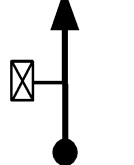

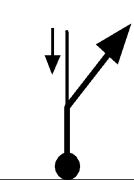
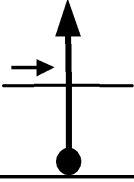
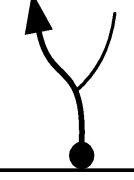
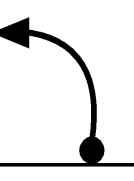
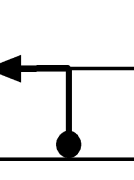
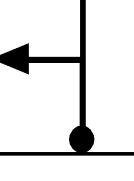
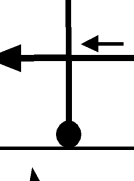
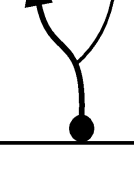
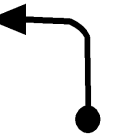

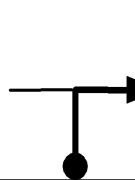
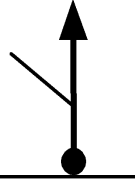
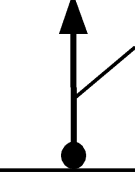
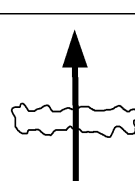
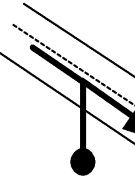
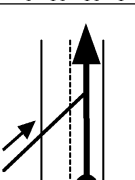
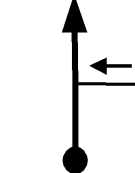
21/10/2017 RINCAO		Pág: 011	
	<b>4.95</b>	V 36	00.27.45
		75	<b>T15</b>
	<b>5.29</b>	V 36	00.28.19
		76	<b>T15</b>
	<b>5.40</b>	V 36	00.28.30
		77	<b>T15</b>
CONTORNE A AGUA			
	<b>5.44</b>	V 36	00.28.34
		78	<b>T15</b>
	<b>5.53</b>	V 36	00.28.43
		79	<b>T15</b>
	<b>5.71</b>	N 1'	00.29.01
		80	<b>T16</b>
	<b>5.71</b>	V 33	00.30.01
		81	<b>T17</b>
	<b>5.84</b>	V 33	00.30.15
		82	<b>T17</b>
BAMP			
	<b>6.00</b>	V 33	00.30.33
		83	<b>T17</b>

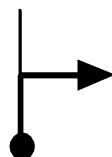

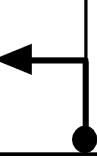
21/10/2017 RINCAO		Pág: 012	
	<b>6.14</b>	V 33	00.30.48
		84	<b>T17</b>
	<b>6.23</b>	V 33	00.30.58
		85	<b>T17</b>
	<b>6.42</b>	V 33	00.31.18
		86	<b>T17</b>
	<b>6.45</b>	V 33	00.31.22
		87	<b>T17</b>
	<b>6.59</b>	V 33	00.31.37
		88	<b>T17</b>
	<b>6.80</b>	V 33	00.32.00
		89	<b>T17</b>
	<b>7.07</b>	V 33	00.32.29
		90	<b>T17</b>
	<b>7.34</b>	V 33	00.32.59
		91	<b>T17</b>
LAJOTA			
	<b>7.75</b>	V 33	00.33.44
		92	<b>T17</b>





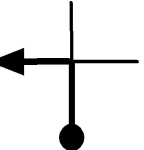

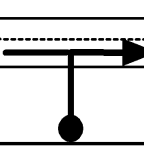
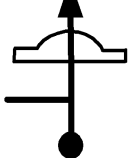
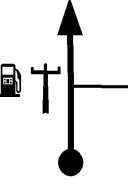
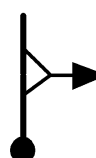
21/10/2017 RINCAO		Pág: 013	
	<b>7.90</b>	V 33	00.34.00
		93	<b>T17</b>
LAGOA			
	<b>8.33</b>	V 33	00.34.47
		94	<b>T17</b>
☠☠☠			
	<b>9.23</b>	V 33	00.36.25
		95	<b>T17</b>
	<b>9.95</b>	V 33	00.37.44
		96	<b>T17</b>
ATENÇÃO			
INICIO DESLOCAMENTO			
☠☠☠			
	<b>11.36</b>	D1'30s	00.40.17
		97	<b>T18</b>
FIM DESLOCAMENTO			
	<b>11.50</b>	V 27	00.41.47
	<b>0.00</b>		
		98	<b>T19</b>
	<b>0.12</b>	V 27	00.42.03
		99	<b>T19</b>

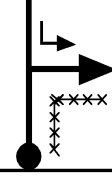
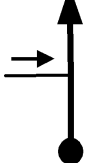
21/10/2017 RINCAO		Pág: 014	
	<b>0.24</b>	V 42	00.42.19
		100	<b>T20</b>
	<b>0.30</b>	V 42	00.42.24
		101	<b>T20</b>
	<b>0.37</b>	V 42	00.42.30
		102	<b>T20</b>
	<b>0.45</b>	V 42	00.42.37
		103	<b>T20</b>
	<b>0.62</b>	V 42	00.42.52
		104	<b>T20</b>
	<b>0.76</b>	V 42	00.43.04
		105	<b>T20</b>
	<b>0.92</b>	V 42	00.43.18
		106	<b>T20</b>
	<b>0.98</b>	V 42	00.43.23
		107	<b>T20</b>
	<b>1.06</b>	V 42	00.43.30
		108	<b>T20</b>

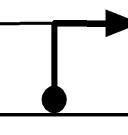
21/10/2017 RINCAO		Pág: 015	
	<b>1.23</b>	V 42	00.43.44
		109	<b>T20</b>
	<b>1.26</b>	V 42	00.43.47
		110	<b>T20</b>
	<b>1.41</b>	V 42	00.44.00
		111	<b>T20</b>
VALO			
	<b>1.66</b>	V 42	00.44.21
		112	<b>T20</b>
ATENÇÃO			
INICIO DESLOCAMENTO			
☠☠☠			
	<b>1.96</b>	D 2'	00.44.47
		113	<b>T21</b>
☠☠☠			
	<b>2.90</b>		
		114	<b>T21</b>
ATENÇÃO			
FIM DESLOCAMENTO			
☠☠☠			
	<b>3.04</b>	V 39	00.46.47
		115	<b>T22</b>

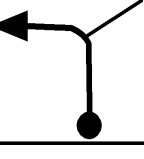
21/10/2017 RINCAO		Pág: 016	
	<b>3.24</b>	V 39	00.47.05
		116	<b>T22</b>
	<b>3.26</b>	V 39	00.47.07
		117	<b>T22</b>
	<b>3.32</b>	V 39	00.47.13
		118	<b>T22</b>
	<b>3.46</b>	V 39	00.47.26
		119	<b>T22</b>
			
	<b>3.63</b>	V 39	00.47.41
		120	<b>T22</b>
	<b>3.79</b>	V 39	00.47.56
		121	<b>T22</b>
	<b>3.97</b>	V 39	00.48.13
		122	<b>T22</b>
	<b>4.13</b>	V 39	00.48.27
		123	<b>T22</b>

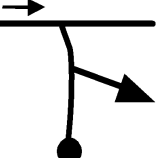

21/10/2017 RINCAO		Pág: 017	
			
	<b>4.22</b>	V 27	00.48.36
		124	<b>T23</b>
	<b>4.36</b>	V 27	00.48.54
		125	<b>T23</b>
	<b>4.92</b>		
	<b>0.00</b>	V 27	00.50.09
		126	<b>T24</b>
	<b>0.23</b>	V 27	00.50.40
		127	<b>T24</b>
FIM ASFALTO			
	<b>0.53</b>	V 27	00.51.20
		128	<b>T24</b>
	<b>1.60</b>	N 1'	00.53.42
		129	<b>T25</b>
	<b>1.60</b>	V 45	00.54.42
		130	<b>T26</b>
	<b>2.29</b>	V 45	00.55.38
		131	<b>T26</b>



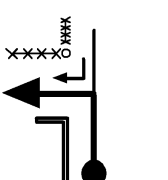
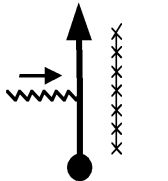
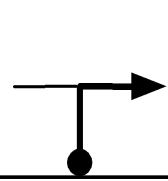
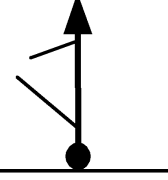
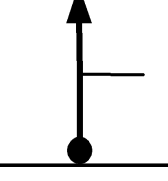

21/10/2017 RINCAO		Pág: 018	
	<b>2.64</b>	V 45	00.56.06
		132	<b>T26</b>
	<b>3.29</b>	V 42	00.56.58
		133	<b>T27</b>
	<b>3.33</b>	V 42	00.57.01
		134	<b>T27</b>
	<b>3.37</b>	V 42	00.57.04
		135	<b>T27</b>
	<b>3.64</b>	V 42	00.57.28
		136	<b>T27</b>
	<b>3.74</b>	V 42	00.57.36
		137	<b>T27</b>
	<b>3.81</b>	V 42	00.57.42
		138	<b>T27</b>
	<b>3.87</b>	V 42	00.57.47
		139	<b>T27</b>
	<b>4.02</b>	V 42	00.58.00
		140	<b>T27</b>

21/10/2017 RINCAO		Pág: 019	
	4.16	V 42	00.58.12
	141	T27	
	4.25	V 42	00.58.20
	142	T27	
	4.36	V 42	00.58.29
	143	T27	
	4.46	V 42	00.58.38
	144	T27	
	4.61	V 42	00.58.51
	145	T27	
	4.63	V 42	00.58.52
	146	T27	
	4.84	V 42	00.59.10
	147	T27	
	5.25	V 42	00.59.46
	148	T27	
	5.27	V 42	00.59.47
	149	T27	

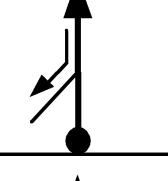
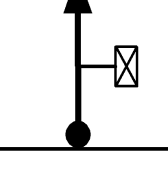
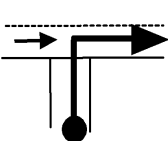
21/10/2017 RINCAO		Pág: 020	
	5.49	V 42	01.00.06
	150	T27	
	5.60	V 42	01.00.16
	151	T27	
	5.63	V 42	01.00.18
	152	T27	
	5.85	V 42	01.00.37
	153	T27	
	5.95	V 42	01.00.46
	154	T27	
	6.00	V 42	01.00.50
	155	T27	
	6.05	V 45	01.00.54
	156	T28	
	6.41	V 45	01.01.23
	157	T28	
	7.11	V 42	01.02.19
	158	T29	

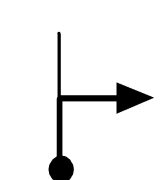
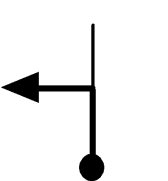
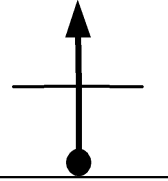
21/10/2017 RINCAO		Pág: 021	
	7.14	V 42	01.02.21
	159	T29	
	7.16	V 42	01.02.23
	160	T29	
	7.38	V 42	01.02.42
	161	T29	
	7.45	V 42	01.02.48
	162	T29	
	7.57	V 42	01.02.58
	163	T29	
	8.07	V 42	01.03.41
	164	T29	
	8.27	V 42	01.03.58
	165	T29	
☠☠☠			
	9.04	N 2'	01.05.04
	166	T30	
☠☠☠			
	9.04		
	0.00	V 45	01.07.04
	167	T31	

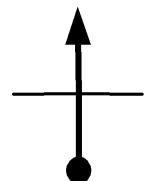
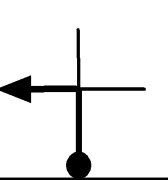
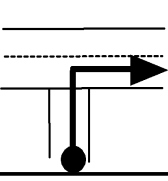
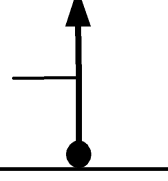
21/10/2017 RINCAO		Pág: 022	
	0.30	V 45	01.07.28
		168	<b>T31</b>
	0.95	V 45	01.08.20
		169	<b>T31</b>
	2.00	V 45	01.09.44
		170	<b>T31</b>
	2.05	V 27	01.09.48
		171	<b>T32</b>
	2.48	V 27	01.10.46
		172	<b>T32</b>
	2.98	N 1'	01.11.52
		173	<b>T33</b>
	2.98	V 27	01.12.52
		174	<b>T34</b>
	3.10	V 27	01.13.08
		175	<b>T34</b>
	3.22	V 27	01.13.24
		176	<b>T34</b>

21/10/2017 RINCAO		Pág: 023	
	3.42	V 33	01.13.51
		177	<b>T35</b>
	3.45	V 33	01.13.54
		178	<b>T35</b>
	3.61	V 33	01.14.12
		179	<b>T35</b>
			
	4.10	V 33	01.15.05
		180	<b>T35</b>
	4.26	V 33	01.15.23
		181	<b>T35</b>
	4.30	V 27	01.15.27
		182	<b>T36</b>
	4.43	V 27	01.15.44
		183	<b>T36</b>
	5.00	N 20'	01.17.00
		184	<b>T37</b>

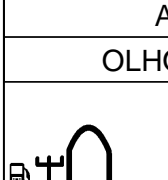
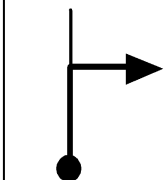
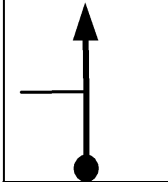
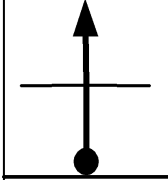
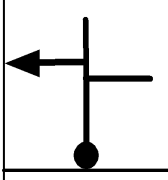
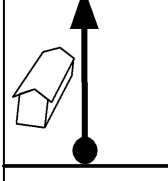
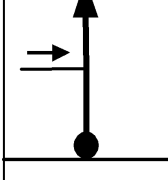
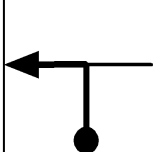





21/10/2017 RINCAO		Pág: 024	
APOIO			
OLHO D'AGUA			
	5.00		
	0.00		
		V 42	01.37.00
		185	<b>T38</b>
	0.56	V 42	01.37.48
		186	<b>T38</b>
	1.06	V 42	01.38.31
		187	<b>T38</b>
	1.94	V 42	01.39.47
		188	<b>T38</b>
	2.12	V 42	01.40.02
		189	<b>T38</b>
	2.30	V 42	01.40.17
		190	<b>T39</b>
	2.68	V 42	01.40.50
		191	<b>T39</b>
	3.00	V 42	01.41.17
		192	<b>T39</b>



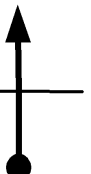
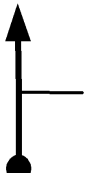

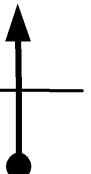





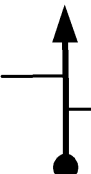





21/10/2017 RINCAO		Pág: 025	
	<b>3.03</b>	V 42	01.41.20
		193	<b>T39</b>
	<b>3.16</b>	V 42	01.41.31
		194	<b>T39</b>
	<b>3.49</b>	V 42	01.41.59
		195	<b>T39</b>
	<b>3.66</b>	V 42	01.42.14
		196	<b>T39</b>
	<b>3.98</b>	V 42	01.42.41
		197	<b>T39</b>
	<b>4.01</b>	V 42	01.42.44
		198	<b>T39</b>
	<b>4.14</b>	V 42	01.42.55
		199	<b>T39</b>
	<b>4.44</b>	V 39	01.43.21
		200	<b>T40</b>
	<b>4.47</b>	V 39	01.43.24
		201	<b>T40</b>

21/10/2017 RINCAO		Pág: 026	
	<b>4.50</b>	V 33	01.43.26
		202	<b>T41</b>
	<b>5.55</b>	V 33	01.45.21
		203	<b>T41</b>
	<b>5.65</b>	N 2'	01.45.32
		204	<b>T42</b>
	<b>5.65</b>	V 33	01.47.32
		205	<b>T43</b>
	<b>5.72</b>	V 33	01.47.39
		206	<b>T43</b>
	<b>5.79</b>	V 33	01.47.47
		207	<b>T43</b>
	<b>6.53</b>	V 33	01.49.08
		208	<b>T43</b>
	<b>6.64</b>	V 39	01.49.20
		209	<b>T44</b>
	<b>7.05</b>	V 39	01.49.58
		210	<b>T44</b>

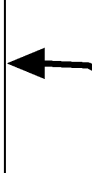
21/10/2017 RINCAO		Pág: 027	
	<b>7.09</b>	V 39	01.50.01
		211	<b>T44</b>
	<b>7.15</b>	V 39	01.50.07
		212	<b>T44</b>
	<b>7.44</b>	V 42	01.50.34
		213	<b>T45</b>
	<b>7.56</b>	V 42	01.50.44
		214	<b>T45</b>
	<b>7.89</b>	V 42	01.51.12
		215	<b>T45</b>
	<b>8.06</b>	V 42	01.51.27
		216	<b>T45</b>
	<b>8.38</b>	V 39	01.51.54
		217	<b>T46</b>
	<b>8.40</b>	V 39	01.51.56
		218	<b>T46</b>
	<b>8.49</b>	V 39	01.52.04
		219	<b>T46</b>

21/10/2017 RINCAO		Pág: 028	
	<b>8.52</b>	V 39	01.52.07
		220	<b>T46</b>
	<b>8.68</b>	V 39	01.52.22
		221	<b>T46</b>
	<b>8.84</b>	V 39	01.52.37
		222	<b>T46</b>
	<b>8.98</b>	N 1'	01.52.50
		223	<b>T47</b>
	<b>8.98</b>	V 39	01.53.50
		224	<b>T48</b>
	<b>9.24</b>	V 39	01.54.14
		225	<b>T48</b>
	<b>9.29</b>	V 39	01.54.18
		226	<b>T48</b>
	<b>9.45</b>	V 39	01.54.33
		227	<b>T48</b>
	<b>9.51</b>	V 39	01.54.39
		228	<b>T48</b>

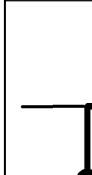
21/10/2017 RINCAO		Pág: 029	
	<b>9.56</b>	V 39	01.54.43
		229	<b>T48</b>
	<b>9.59</b>	V 39	01.54.46
		230	<b>T48</b>
	<b>9.64</b>	V 42	01.54.51
		231	<b>T49</b>
	<b>9.81</b>	V 42	01.55.05
		232	<b>T49</b>
	<b>10.01</b>	V 42	01.55.22
		233	<b>T49</b>
	<b>10.15</b>	V 45	01.55.34
		234	<b>T50</b>
	<b>10.70</b>	V 45	01.56.18
		235	<b>T50</b>
	<b>10.81</b>	V 45	01.56.27
		236	<b>T50</b>
	<b>10.99</b>	V 45	01.56.41
		237	<b>T50</b>

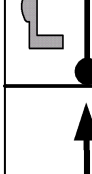
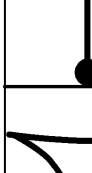
21/10/2017 RINCAO		Pág: 030	
	<b>11.07</b>	V 45	01.56.48
		238	<b>T50</b>
	<b>11.13</b>	V 45	01.56.53
		239	<b>T50</b>
			
	<b>11.50</b>	N 1'	01.57.22
		240	<b>T51</b>
			
	<b>11.50</b>	<b>0.00</b>	V 51 01.58.22
		241	<b>T52</b>
	<b>0.94</b>	V 51	01.59.29
		242	<b>T52</b>
	<b>1.79</b>	V 51	02.00.29
		243	<b>T52</b>
	<b>2.60</b>	V 51	02.01.26
		244	<b>T52</b>

21/10/2017 RINCAO		Pág: 031	
	<b>2.97</b>	V 51	02.01.52
		245	<b>T52</b>
	<b>3.11</b>	V 51	02.02.02
		246	<b>T52</b>
	<b>4.25</b>	V 51	02.03.22
		247	<b>T52</b>
	<b>4.38</b>	V 51	02.03.31
		248	<b>T52</b>
	<b>4.75</b>	V 51	02.03.58
		249	<b>T52</b>
	<b>4.87</b>	V 36	02.04.06
		250	<b>T53</b>
	<b>4.99</b>	V 36	02.04.18
		251	<b>T53</b>
MOTO CONTRA			
	<b>5.14</b>	V 36	02.04.33
		252	<b>T53</b>
	<b>5.23</b>	V 36	02.04.42
		253	<b>T53</b>

21/10/2017 RINCAO		Pág: 032	
	<b>5.61</b>	V 21	02.05.20
		254	<b>T54</b>
MOTO CONTRA			
	<b>5.70</b>	V 36	02.05.35
		255	<b>T55</b>
MOTO CONTRA			
	<b>6.05</b>	V 36	02.06.10
		256	<b>T55</b>
	<b>6.15</b>	V 36	02.06.20
		257	<b>T55</b>
	<b>6.17</b>	V 36	02.06.22
		258	<b>T55</b>
	<b>6.29</b>	V 36	02.06.34
		259	<b>T55</b>
	<b>6.31</b>	V 18	02.06.36
		260	<b>T56</b>
	<b>6.33</b>	V 18	02.06.40
		261	<b>T56</b>

21/10/2017 RINCAO		Pág: 033	
	<b>6.36</b>	V 24	02.06.46
		262	<b>T57</b>
	<b>6.40</b>	V 24	02.06.52
		263	<b>T57</b>
	<b>6.51</b>	V 33	02.07.09
		264	<b>T58</b>
	<b>6.55</b>	V 33	02.07.13
		265	<b>T58</b>
	<b>6.59</b>	V 33	02.07.18
		266	<b>T58</b>
	<b>6.68</b>	V 33	02.07.27
		267	<b>T58</b>
SIGA BAMP			
	<b>6.72</b>	V 33	02.07.32
		268	<b>T58</b>
	<b>6.81</b>	V 36	02.07.42
		269	<b>T59</b>
	<b>6.94</b>	V 36	02.07.55
		270	<b>T59</b>

21/10/2017 RINCAO		Pág: 034	
	<b>7.03</b>	V 36	02.08.04
		271	<b>T59</b>
	<b>7.06</b>	V 36	02.08.07
		272	<b>T59</b>
	<b>7.18</b>	V 30	02.08.19
		273	<b>T60</b>
	<b>7.20</b>	V 30	02.08.21
		274	<b>T60</b>
	<b>7.27</b>	V 30	02.08.29
		275	<b>T60</b>
	<b>7.29</b>	V 30	02.08.32
		276	<b>T60</b>
	<b>7.34</b>	V 30	02.08.38
		277	<b>T60</b>
	<b>7.43</b>	V 30	02.08.49
		278	<b>T60</b>
	<b>7.48</b>	V 30	02.08.55
		279	<b>T60</b>

21/10/2017 RINCAO		Pág: 035	
	<b>7.50</b>	V 18	02.08.57
		280	<b>T61</b>
	<b>7.53</b>	V 18	02.09.03
		281	<b>T61</b>
	<b>7.55</b>	V 18	02.09.07
		282	<b>T61</b>
DESCE BARRANCO			
	<b>7.56</b>	V 24	02.09.09
		283	<b>T62</b>
	<b>7.59</b>	V 24	02.09.14
		284	<b>T62</b>
	<b>7.70</b>	V 33	02.09.30
		285	<b>T63</b>
☠☠☠			
	<b>7.74</b>	V 33	02.09.34
		286	<b>T63</b>
	<b>7.83</b>	V 33	02.09.44
		287	<b>T63</b>
	<b>7.94</b>	V 33	02.09.56
		288	<b>T63</b>

21/10/2017 RINCAO		Pág: 036	
	<b>8.06</b>	V 42	02.10.09
		289	<b>T64</b>
	<b>8.67</b>	V 18	02.11.02
		290	<b>T65</b>
	<b>8.77</b>	V 33	02.11.22
		291	<b>T66</b>
☠☠☠			
	<b>9.12</b>	V 33	02.12.00
		292	<b>T66</b>
	<b>9.21</b>	V 33	02.12.10
		293	<b>T66</b>
	<b>9.23</b>	V 33	02.12.12
		294	<b>T66</b>
	<b>9.35</b>	V 33	02.12.25
		295	<b>T66</b>
	<b>9.37</b>	V 18	02.12.27
		296	<b>T67</b>
	<b>9.41</b>	V 18	02.12.35
		297	<b>T67</b>

21/10/2017 RINCAO		Pág: 037	
	9.42	V 24	02.12.37
	298	<b>T68</b>	
	9.46	V 24	02.12.43
	299	<b>T68</b>	
	9.57	V 33	02.13.00
	300	<b>T69</b>	
	9.61	V 33	02.13.04
	301	<b>T69</b>	
	9.70	V 27	02.13.14
	302	<b>T70</b>	
	9.92	V 27	02.13.43
	303	<b>T70</b>	
	9.96	V 27	02.13.48
	304	<b>T70</b>	
	10.00	V 27	02.13.54
	305	<b>T70</b>	



21/10/2017 RINCAO		Pág: 038	
	10.07	V 27	02.14.03
	306	<b>T70</b>	
	10.20	V 27	02.14.20
	307	<b>T70</b>	
	10.22	V 18	02.14.23
	308	<b>T71</b>	
	10.24	V 18	02.14.27
	309	<b>T71</b>	
	10.26	V 24	02.14.31
	310	<b>T72</b>	
	10.28	V 24	02.14.34
	311	<b>T72</b>	
	10.31	V 24	02.14.39
	312	<b>T72</b>	
	10.42	V 33	02.14.55
	313	<b>T73</b>	
	10.46		
	0.00		
		V 39	02.14.59
	314	<b>T74</b>	





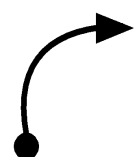
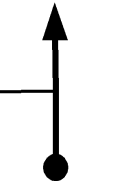
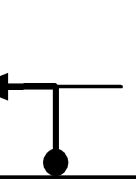
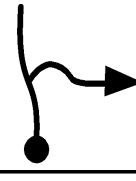
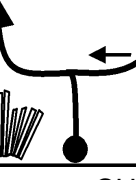

21/10/2017 RINCAO		Pág: 039	
	0.09	N 3'	02.15.08
	315	<b>T75</b>	
	0.09	V 39	02.18.08
	316	<b>T76</b>	
	0.68	V 48	02.19.02
	317	<b>T77</b>	
	1.81	V 48	02.20.27
	318	<b>T77</b>	
	2.41	V 48	02.21.12
	319	<b>T77</b>	
	3.83	V 48	02.22.58
	320	<b>T77</b>	
	4.32	V 33	02.23.35
	321	<b>T78</b>	
ATENÇÃO			
MOTO CONTRA			
	5.14	V 24	02.25.05
	322	<b>T79</b>	

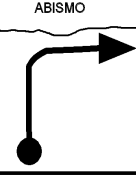
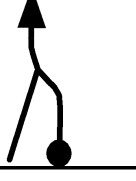
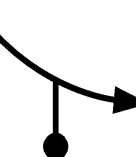
21/10/2017 RINCAO		Pág: 040	
	<b>5.24</b>	V 24	02.25.20
		323	<b>T79</b>
	<b>5.29</b>	V 24	02.25.27
		324	<b>T79</b>
	<b>5.39</b>	V 15	02.25.42
		325	<b>T80</b>
	<b>5.44</b>	V 15	02.25.54
		326	<b>T80</b>
	<b>5.54</b>	V 21	02.26.18
		327	<b>T81</b>
<b>MOTO CONTRA</b>			
	<b>5.70</b>	V 18	02.26.46
		328	<b>T82</b>
	<b>5.85</b>	V 12	02.27.16
		329	<b>T83</b>
	<b>5.94</b>	V 12	02.27.43
		330	<b>T83</b>
	<b>6.00</b>	V 12	02.28.01
		331	<b>T83</b>

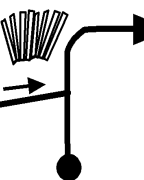
21/10/2017 RINCAO		Pág: 041	
<b>CUIDADO!</b>			
<b>VALO</b>			
	<b>6.05</b>	V 18	02.28.16
		332	<b>T84</b>
	<b>6.09</b>	V 18	02.28.24
		333	<b>T84</b>
<b>MOURÃO</b>			
	<b>6.15</b>	V 18	02.28.36
		334	<b>T84</b>
	<b>6.29</b>	V 12	02.29.04
		335	<b>T85</b>
	<b>6.38</b>	V 15	02.29.31
		336	<b>T86</b>
	<b>6.42</b>	V 15	02.29.40
		337	<b>T86</b>
	<b>7.52</b>	V 15	02.34.04
		338	<b>T86</b>
	<b>7.71</b>	V 24	02.34.50
		339	<b>T87</b>

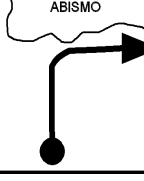
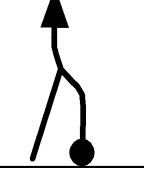
21/10/2017 RINCAO		Pág: 042	
	<b>7.75</b>	V 24	02.34.56
		340	<b>T87</b>
	<b>7.79</b>	N 3'	02.35.02
		341	<b>T88</b>
	<b>7.79</b>	V 24	02.38.02
		342	<b>T89</b>
	<b>7.94</b>	V 24	02.38.24
		343	<b>T89</b>
	<b>8.03</b>	V 24	02.38.38
		344	<b>T89</b>
	<b>8.08</b>	V 33	02.38.45
		345	<b>T90</b>
	<b>8.16</b>	V 33	02.38.54
		346	<b>T90</b>
	<b>8.31</b>	V 33	02.39.10
		347	<b>T90</b>
	<b>8.38</b>	V 27	02.39.18
		348	<b>T91</b>

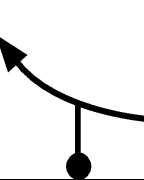
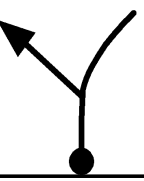
21/10/2017 RINCAO		Pág: 043	
	<b>9.12</b>	V 33	02.40.57
		349	<b>T92</b>
	<b>9.20</b>	V 33	02.41.05
		350	<b>T92</b>
	<b>9.46</b>	V 33	02.41.34
		351	<b>T92</b>
	<b>9.60</b>	V 27	02.41.49
		352	<b>T93</b>
	<b>9.87</b>	V 33	02.42.25
		353	<b>T94</b>
<b>CUIDADO!</b>			
<b>ABISMO</b>			
			
	<b>10.06</b>	V 33	02.42.46
		354	<b>T94</b>
	<b>10.09</b>	V 33	02.42.49
		355	<b>T94</b>
	<b>10.40</b>	V 33	02.43.23
		356	<b>T94</b>

21/10/2017 RINCAO		Pág: 044	
	<b>10.81</b>	V 33	02.44.08
		357	<b>T94</b>
<b>CUIDADO!</b>			
<b>ABISMO</b>			
			
	<b>11.00</b>	V 33	02.44.28
		358	<b>T94</b>
	<b>11.03</b>	V 33	02.44.32
		359	<b>T94</b>
			
	<b>11.34</b>	N 1'	02.45.05
		360	<b>T95</b>
	<b>11.34</b>	V 36	02.46.05
		361	<b>T96</b>
	<b>11.36</b>	V 36	02.46.07
		362	<b>T96</b>
	<b>11.50</b>	V 36	02.46.21
		363	<b>T96</b>

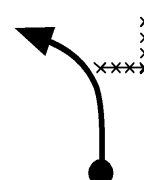
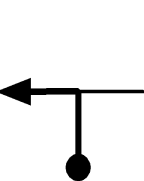
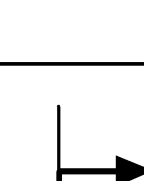
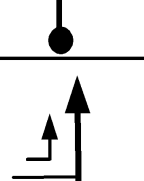
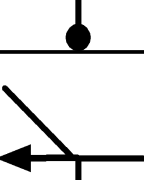
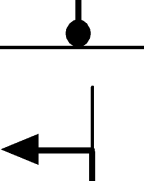
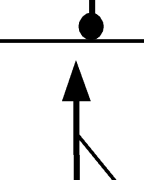
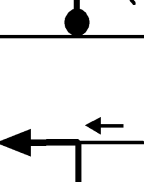
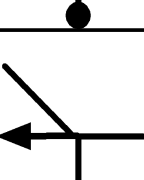



21/10/2017 RINCAO		Pág: 045	
	<b>11.67</b>	V 36	02.46.38
		364	<b>T96</b>
	<b>11.75</b>		
	<b>0.00</b>	V 33	02.46.46
		365	<b>T97</b>
	<b>0.22</b>	V 15	02.47.10
		366	<b>T98</b>
	<b>0.31</b>	V 42	02.47.32
		367	<b>T99</b>
	<b>0.52</b>	V 42	02.47.50
		368	<b>T99</b>
	<b>0.86</b>	V 42	02.48.19
		369	<b>T99</b>
	<b>0.91</b>	V 42	02.48.23
		370	<b>T99</b>
	<b>1.39</b>	V 42	02.49.05
		371	<b>T99</b>
	<b>1.61</b>	V 42	02.49.23
		372	<b>T99</b>

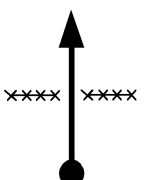

21/10/2017 RINCAO		Pág: 046	
	1.95	V 42	02.49.53
		373	T99
	2.00	V 33	02.49.57
		374	T100
	2.06	V 33	02.50.03
		375	T100
	2.23	V 33	02.50.22
		376	T100
	2.26	V 33	02.50.25
		377	T100
	2.72	N 1'	02.51.15
		378	T101
	2.72	V 39	02.52.15
		379	T102
	3.17	V 39	02.52.57
		380	T102
	3.26	V 27	02.53.05
		381	T103

21/10/2017 RINCAO		Pág: 047	
	3.40	V 27	02.53.24
		382	T103
	3.54	V 27	02.53.43
		383	T103
	3.62	V 42	02.53.53
		384	T104
	4.55	V 45	02.55.13
		385	T105
	5.16	V 45	02.56.02
		386	T105
	5.35	N 1'	02.56.17
		387	T106
	5.35	V 33	02.57.17
		388	T107
	5.47	V 33	02.57.30
		389	T107
	5.60	V 33	02.57.44
		390	T107

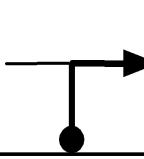
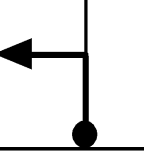
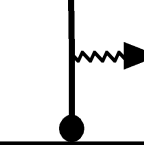
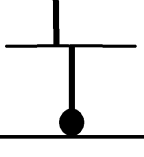
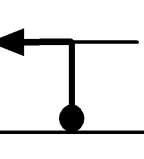
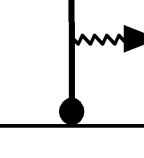
21/10/2017 RINCAO		Pág: 048	
	5.70	V 33	02.57.55
		391	T107
	5.85	V 33	02.58.11
		392	T107
	6.03	V 39	02.58.31
		393	T108
	6.08	V 39	02.58.36
		394	T108
	6.17	V 39	02.58.44
		395	T108
	6.36	V 39	02.59.02
		396	T108
	6.50	V 39	02.59.14
		397	T108
	6.70	V 39	02.59.33
		398	T108
	6.87	V 39	02.59.49
		399	T108

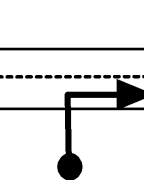
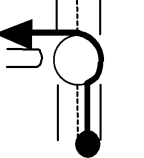
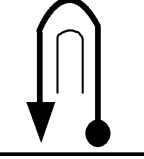
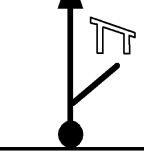
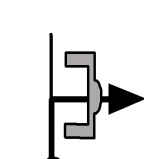

21/10/2017 RINCAO		Pág: 049	
	<b>7.30</b>	V 39	03.00.28
		400	<b>T108</b>
		<b>7.37</b>	N1'30s
		401	<b>T109</b>
	<b>7.37</b>	V 30	03.02.05
		402	<b>T110</b>
		<b>7.46</b>	V 30
		403	<b>T110</b>
		<b>7.64</b>	V 30
		404	<b>T110</b>
		<b>7.73</b>	V 30
		405	<b>T110</b>
		<b>7.93</b>	V 30
		406	<b>T110</b>
		<b>7.95</b>	V 30
		407	<b>T110</b>
		<b>8.16</b>	N 1'
		408	<b>T111</b>

21/10/2017 RINCAO		Pág: 050	
	<b>8.16</b>	V 27	03.04.40
		409	<b>T112</b>
		<b>8.30</b>	V 27
		410	<b>T112</b>
		<b>8.54</b>	V 27
		411	<b>T112</b>
		<b>8.64</b>	V 27
		412	<b>T112</b>
FIM DE PROVA			
	<b>8.67</b>	V 27	03.05.48
		413	<b>T112</b>
	<b>FIM DE PROVA !!</b>		
			
<a href="http://www.t15.com.br">www.t15.com.br</a>			
Obrigado pela sua participação			
Ate a proxima			
Tenha uma boa viagem de volta para sua casa!!!			
<b>Tempo de Prova</b>			
MÉDIA C 03:05:48			

21/10/2017 RINCAO		Pág: 051	
<b>FIM</b>			