

**INICIO**

**MÉDIA B**

ENDURO TRILHEIROS DO RIO  
16 DE JUNHO DE 2018



**IMPORTANTE**

PLANILHA TERMICA  
FITA ADESIVA DO LADO DE  
TRÁS. NÃO USE CANETA  
MARCA TEXTO,  
USE CANETA ESFEROGRÁFICA

OU HIDROGRÁFICA

-----  
DIRETORES DE PROVA:  
SAMUEL  
GUSTAVO

REALIZAÇÃO:  
EQUIPE TRILHEIROS DO RIO

NOS TRECHOS URBANOS  
PREVALECEM AS LEIS DO  
CÓDIGO NACIONAL DE  
TRANSITO. É OBRIGAÇÃO  
RESPEITAR AS  
PROPRIEDADES  
ALHEIAS E OS MORADORES.  
A ORGANIZAÇÃO NÃO SE  
RESPONSABILIZA POR  
PASSAR  
PROGRAMAÇÃO DE  
NAVEGAÇÃO.  
É OBRIGAÇÃO DO PILOTO  
CONFERIR A PROGRAMAÇÃO  
DO  
NAVEGADOR.

LARGADA - 14:00 HS  
NEUTRO PRINCIPAL  
EMPRESA RIO TELAS  
CHEGADA NO MESMO  
LOCAL DA LARGADA

1 ETAPA KM 29,63  
2 ETAPA KM 32,68  
TOTAL KM 62,31

LEVANTAMENTO DA PROVA  
COM MOTO WR 250F COM  
PNEU DIANTEIRO BOM  
E 11 LIBRAS

☠	CUIDADO
☠☠	ATENÇÃO
☠☠☠	MUITA ATENÇÃO

## Tempo de Prova

MÉDIA B 02:53:56



## AFERIÇÃO

	0.00
	0.00
	1 AFER
	0.13
	2 AFER
	0.29
	3 AFER
	0.59
	4 AFER
	1.07
	5 AFER

	1.23
	0.00
	6 AFER



**INICIO DE PROVA**

	0.00
	V 24 00:00:00
	7 T1

	0.13
	V 39 00:00:20
	8 T2

	0.29
	V 39
	9 T2

	0.59
	V 39
	10 T2

	1.07
	V 39
	11 T2

	1.23	
	D 2'	00:02:01
	12	<b>T3</b>

FIM DESLOCAMENTO

	1.64	
	V 36	00:04:01
	13	<b>T4</b>

	2.32	
	V 36	
	14	<b>T4</b>

	2.35	
	V 36	
	15	<b>T4</b>

BAMP

	2.65	
	V 36	
	16	<b>T4</b>

BAMP

	2.83	
	V 36	
	17	<b>T4</b>

BAMP

	2.96	
	V 36	
	18	<b>T4</b>

	3.16
	V 27 00:06:33
	19 <b>T5</b>

Andar pelo trilho

	3.23
	V 27
	20 <b>T5</b>

	3.42
	V 27
	21 <b>T5</b>

	3.65
	V 27
	22 <b>T5</b>

	3.77
	V 21 00:07:54
	23 <b>T6</b>

	4.07
	V 21
	24 <b>T6</b>

	4.10
	V 21
	25 <b>T6</b>

	4.17
	V 36 00:09:03
	26 <b>T7</b>

	4.57	
	V 36	
	27	T7

	5.74	
	V 36	
	28	T7

	5.83	
	V 36	
	29	T7

	6.16	
	V 18	00:12:22
	30	<b>T8</b>

	6.35	
	V 18	
	31	T8

	6.44	
	V 18	
	32	T8

SOBE

	6.85	
	V 33	00:14:40
	33	<b>T9</b>

	7.77	
	V 33	
	34	T9

	7.91	
	N 2'	00:16:36
	35	<b>T10</b>

	7.91	
	V 33	00:18:36
	36	<b>T11</b>

	7.96	
	<b>0.00</b>	
	V 33	00:18:41
	37	<b>T12</b>

	0.18	
	V 33	
	38	<b>T12</b>

	0.31	
	V 42	00:19:15
	39	<b>T13</b>

	0.76	
	V 42	
	40	<b>T13</b>

	1.28	
	V 30	00:20:38
	41	<b>T14</b>

	1.48	
	V 30	
	42	<b>T14</b>

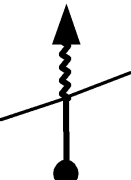
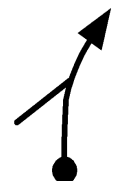
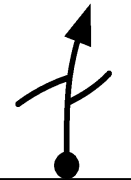
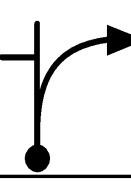
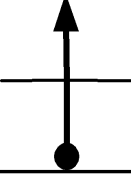
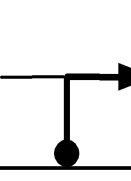
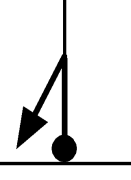
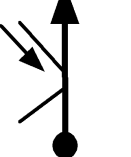
	1.70
	V 30
	43 T14
	1.87
	V 30
	44 T14
	1.93
	V 30
	45 T14
	2.01
	V 21 00:22:06
	46 T15
	2.05
	V 21
	47 T15
	2.09
	V 21
	48 T15
	2.12
	V 21
	49 T15
	2.18
	V 21
	50 T15



	2.26	
	V 21	
	51	T15
	2.28	
	V 21	
	52	T15
	2.31	
	V 21	
	53	T15
	2.40	
	V 21	
	54	T15
	2.46	
	V 21	
	55	T15
	2.72	
	V 21	
	56	T15
	2.98	
	V 18	00:24:52
	57	T16
	3.07	
	V 18	
	58	T16

	3.12	
	V 18	
	59	T16



	3.31	
	V 18	
	60	T16

	3.38	
	V 18	
	61	T16



	3.47	
	V 18	
	62	T16

	4.38	
	N 3'	00:29:32
	63	T17

	4.38	
	V 27	00:32:32
	64	T18

	4.55	
	V 27	
	65	T18

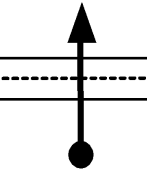
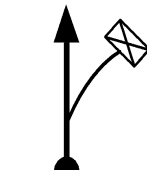
	4.69	
	V 27	
	66 T18	
	4.80	
	V 30 00:33:28	
	67 T19	
	4.85	
	V 30	
	68 T19	
	5.05	
	V 30	
	69 T19	
	5.26	
	V 30	
	70 T19	
	5.84	
	V 30	
	71 T19	
	6.10	
	0.00	
	V 33 00:36:04	
	72 T20	
	0.52	
	N1'30s00:37:01	
	73 T21	

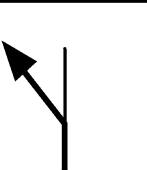
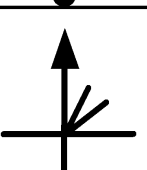
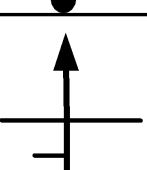
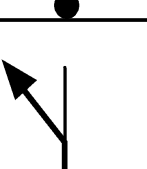
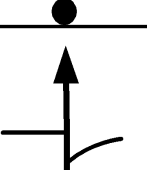
	0.52
	V 21 00:38:31
	74 T22
	1.69
	V 39 00:41:51
	75 T23
	1.93
	V 39
	76 T23
	2.08
	V 27 00:42:27
	77 T24
	2.41
	V 27
	78 T24
	2.47
	V 27
	79 T24
	2.50
	V 27
	80 T24
	2.81
	V 21 00:44:04
	81 T25

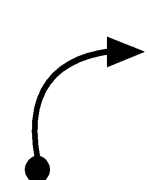
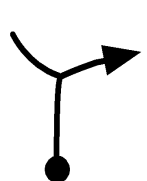
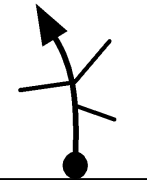
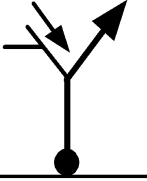
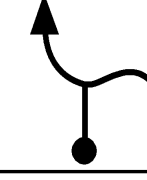
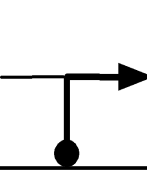
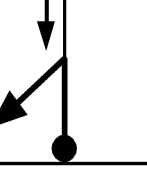
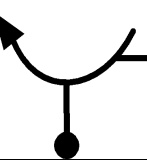
	3.49	
	V 21	
	82	T25
	3.52	
	V 21	
	83	T25
	4.38	
	V 21	
	84	T25
	4.57	
	V 21	
	85	T25
	4.65	
	V 21	
	86	T25
	4.67	
	V 21	
	87	T25
	4.78	
	V 21	
	88	T25
	4.91	
	V 21	
	89	T25

	5.02
	N 2' 00:50:23
	90 <b>T26</b>
	5.02
	V 18 00:52:23
	91 <b>T27</b>
	5.13
	0.00
	V 21 00:52:45
	0.69
	V 21
	93 <b>T28</b>
	0.77
	V 21
	94 <b>T28</b>
	0.83
	V 21
	95 <b>T28</b>
	1.51
	V 21
	96 <b>T28</b>
	1.56
	V 21
	97 <b>T28</b>

	1.70
	V 21
	98 <b>T28</b>
	1.94
	V 21
	99 <b>T28</b>
	2.28
	V 21
	100 <b>T28</b>
	2.44
	V 21
	101 <b>T28</b>
	2.46
	V 21
	102 <b>T28</b>
	2.70
	V 21
	103 <b>T28</b>
	2.86
	V 21
	104 <b>T28</b>
	3.19
	V 21
	105 <b>T28</b>

	3.35	
	V 21	
	106	<b>T28</b>
	3.40	
	V 21	
	107	<b>T28</b>
	3.47	
	V 21	
	108	<b>T28</b>
	3.57	
	V 21	
	109	<b>T28</b>
	3.59	
	V 21	
	110	<b>T28</b>
	3.68	
	V 21	
	111	<b>T28</b>
	3.76	
	V 21	
	112	<b>T28</b>
	3.77	
	V 21	
	113	<b>T28</b>



	3.79	
	V 21	
	114	<b>T28</b>

	3.88	
	V 21	
	115	<b>T28</b>

	3.93	
	V 21	
	116	<b>T28</b>

	3.95	
	V 21	
	117	<b>T28</b>

	3.98	
	V 21	
	118	<b>T28</b>





	4.14	
	V 21	
	119	<b>T28</b>



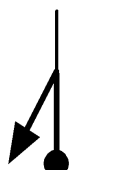
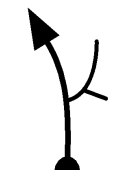
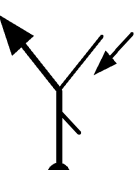
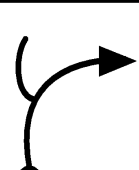
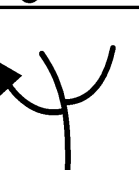
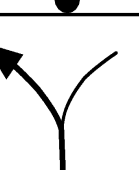
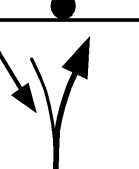
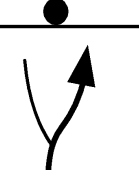

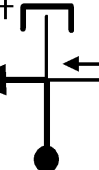

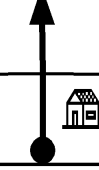

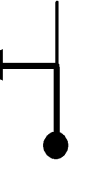

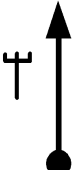
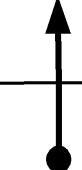
	4.18	
	V 21	
	120	<b>T28</b>

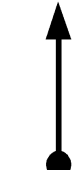
	4.44
	V 21
	121 T28
	4.49
	N 2' 01:05:35
	122 T29
	4.49
	0.00
	V 39 01:07:35
	0.13
	V 39
	124 T30
	0.30
	V 39
	125 T30
	0.77
	V 39
	126 T30
	1.68
	V 39
	127 T30
	2.15
	V 39
	128 T30

	2.35	
	V 27	01:11:12
	129	<b>T31</b>
	2.62	
	V 27	
	130	<b>T31</b>
	2.70	
	V 27	
	131	<b>T31</b>
	2.77	
	V 27	
	132	<b>T31</b>
	2.83	
	V 27	
	133	<b>T31</b>
	2.89	
	V 27	
	134	<b>T31</b>
	2.91	
	V 27	
	135	<b>T31</b>
	3.00	
	V 27	
	136	<b>T31</b>

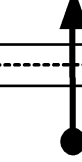
	3.03
	V 27
	137 T31
	3.15
	V 39 01:12:59
	138 T32
	4.27
	V 30 01:14:42
	139 T33
	4.98
	V 30
	140 T33
	5.18
	V 30
	141 T33
	5.79
	V 30
	142 T33
FIM 1ª ETAPA	
NEUTRO PRINCIPAL	
	5.95
	0.00
	N 6'30 01:18:04
	143 T34

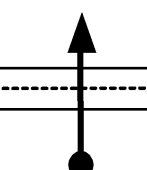
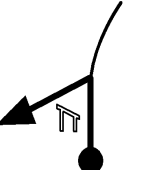
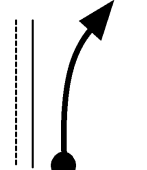
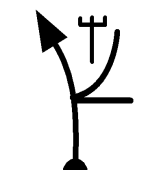
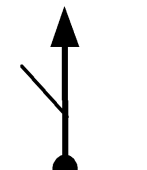
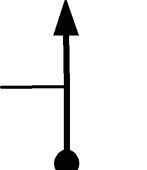
	0.00
	V 30 01:34:34
	144 <b>T35</b>
	0.31
	V 30
	145 <b>T35</b>
	0.57
	V 30
	146 <b>T35</b>
DESCE	
	0.79
	V 21 01:36:08
	147 <b>T36</b>
	0.82
	V 21
	148 <b>T36</b>
	1.08
	V 30 01:36:58
	149 <b>T37</b>
	1.31
	0.00
	V 21 01:37:26
	150 <b>T38</b>
	
	0.42
	N 2' 01:38:38
	151 <b>T39</b>

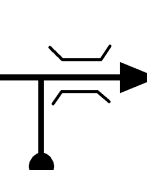
	<p>0.42</p> <p>V 30 01:40:38</p> <p>152 <b>T40</b></p>
	<p>0.55</p> <p>V 30</p> <p>153 <b>T40</b></p>
	<p>0.76</p> <p>V 30</p> <p>154 <b>T40</b></p>
	<p>1.41</p> <p>V 30</p> <p>155 <b>T40</b></p>
	<p>1.56</p> <p>V 30</p> <p>156 <b>T40</b></p>
	<p>1.80</p> <p>V 30</p> <p>157 <b>T40</b></p>
	<p>1.86</p> <p>V 30</p> <p>158 <b>T40</b></p>
	<p>2.24</p> <p>V 39 01:44:16</p> <p>159 <b>T41</b></p>

	2.36	
	V 39	
	160	<b>T41</b>
	3.08	
	V 39	
	161	<b>T41</b>
	3.27	
	V 39	
	162	<b>T41</b>
	3.51	
	0.00	
	V 21	01:46:13
	163	<b>T42</b>
	0.02	
	V 21	
	164	<b>T42</b>
	0.21	
	V 27	01:46:49
	165	<b>T43</b>
	0.39	
	V 27	
	166	<b>T43</b>
	0.50	
	V 27	
	167	<b>T43</b>

	0.91	
	V 27	
	168	<b>T43</b>
	1.01	
	V 27	
	169	<b>T43</b>
	1.18	
	V 27	
	170	<b>T43</b>
	1.23	
	N1'30:01:49:05	
	171	<b>T44</b>
	1.23	
	V 33 01:50:35	
	172	<b>T45</b>
	1.41	
	V 33	
	173	<b>T45</b>
	1.55	
	V 33	
	174	<b>T45</b>
	1.75	
	V 27 01:51:32	
	175	<b>T46</b>



	1.93	
	V 27	
	176	<b>T46</b>

	2.04	
	V 27	
	177	<b>T46</b>

	2.45	
	V 27	
	178	<b>T46</b>

	2.65	
	V 27	
	179	<b>T46</b>



	2.68	
	V 27	
	180	<b>T46</b>

	2.81	
	V 27	
	181	<b>T46</b>

	2.92	
	V 27	
	182	<b>T46</b>

	3.05	
	V 27	
	183	<b>T46</b>

	3.18	
	V 27	
	184	<b>T46</b>

	3.29	
	V 27	
	185	<b>T46</b>

Siga os BAMPS

	3.72	
	V 27	
	186	<b>T46</b>

	3.77	
	V 27	
	187	<b>T46</b>

	3.81	
	N 2'	01:56:07
	188	<b>T47</b>

	3.81	
	V 33	01:58:07
	189	<b>T48</b>

COSTEAR BARRANCO

	3.90	
	V 33	
	190	<b>T48</b>

	4.07	
	V 27	01:58:35
	191	<b>T49</b>
	4.24	
	V 27	
	192	<b>T49</b>
	4.30	
	V 27	
	193	<b>T49</b>
	4.54	
	V 18	01:59:38
	194	<b>T50</b>
	4.63	
	V 18	
	195	<b>T50</b>
	4.94	
	V 27	02:00:58
	196	<b>T51</b>
	4.97	
	V 27	
	197	<b>T51</b>
	5.24	
	V 30	02:01:38
	198	<b>T52</b>

	5.60
	0.00
	V 39 02:02:21
199	<b>T53</b>
	0.03
	V 39
	200
	0.16
	V 39
	201
	0.44
	V 27 02:03:02
	202
	0.57
	V 27
	203
	0.67
	V 27
	204
	0.72
	V 27
	205
	0.75
	V 27
	206

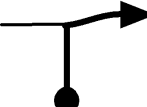
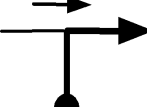
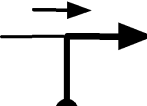
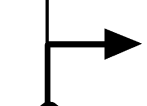
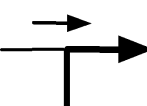
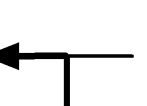
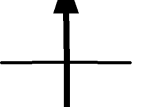
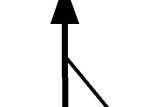
	0.96	
	V 27	
	207	<b>T54</b>
	1.08	
	N 2'	02:04:27
	208	<b>T55</b>
	1.08	
	V 27	02:06:27
	209	<b>T56</b>
	1.11	
	V 30	02:06:31
	210	<b>T57</b>
	1.25	
	V 30	
	211	<b>T57</b>
	1.32	
	V 30	
	212	<b>T57</b>
	1.35	
	V 30	
	213	<b>T57</b>
	1.42	
	V 30	
	214	<b>T57</b>

	1.46
	V 30
	215 T57
	1.54
	V 30
	216 T57
	1.60
	V 30
	217 T57
	1.64
	V 24 02:07:34
	218 T58
	1.71
	V 24
	219 T58
	1.80
	V 24
	220 T58
	1.92
	V 24
	221 T58
	1.95
	V 24
	222 T58

	2.13	
	V 24	
	223	<b>T58</b>
	2.22	
	V 24	
	224	<b>T58</b>
	2.28	
	V 24	
	225	<b>T58</b>
	2.45	
	V 24	
	226	<b>T58</b>
	2.61	
	V 27	02:10:00
	227	<b>T59</b>
	2.63	
	V 27	
	228	<b>T59</b>
	2.66	
	V 27	
	229	<b>T59</b>
	2.77	
	V 27	
	230	<b>T59</b>

	2.82
	V 27
	231 T59
	2.86
	V 27
	232 T59
	3.04
	V 27
	233 T59
	3.10
	V 24 02:11:05
	234 T60
	3.39
	V 24
	235 T60
	3.55
	V 24
	236 T60
	3.65
	N1'30 02:12:28
	237 T61
	3.65
	V 30 02:13:58
	238 T62



	3.82	
	V 36	02:14:18
	239	<b>T63</b>



	3.90	
	V 36	
	240	<b>T63</b>

	4.28	
	V 36	
	241	<b>T63</b>

	4.47	
	V 36	
	242	<b>T63</b>

	4.67	
	V 36	
	243	<b>T63</b>

	4.83	
	V 36	
	244	<b>T63</b>



	5.00	
	V 36	
	245	<b>T63</b>

	5.38	
	V 36	
	246	<b>T63</b>
	5.56	
	V 36	
	247	<b>T63</b>
	5.71	
	V 36	
	248	<b>T63</b>
	5.89	
	V 36	
	249	<b>T63</b>
	5.94	
	V 24	02:17:50
	250	<b>T64</b>
	6.04	
	V 24	
	251	<b>T64</b>
	6.57	
	V 24	
	252	<b>T64</b>
	6.61	
	V 24	
	253	<b>T64</b>

	6.70	
	V 24	
	254	<b>T64</b>
	6.73	
	V 24	
	255	<b>T64</b>
	6.83	
	V 24	
	256	<b>T64</b>
	6.98	
	V 24	
	257	<b>T64</b>
	7.21	
	0.00	
	N 2'	02:21:01
	258	<b>T65</b>
	0.00	
	V 33	02:23:01
	259	<b>T66</b>
	0.34	
	V 33	
	260	<b>T66</b>
	0.59	
	V 33	
	261	<b>T66</b>

	0.89	
	V 33	
	262	<b>T66</b>
	1.17	
	V 33	
	263	<b>T66</b>
	1.91	
	V 42	02:26:29
	264	<b>T67</b>
	4.10	
	V 42	
	265	<b>T67</b>
	4.90	
	<b>0.00</b>	
	V 42	02:30:45
	0.77	
	V 15	02:31:51
	267	<b>T69</b>
	1.11	
	V 15	
	268	<b>T69</b>
	1.16	
	V 30	02:33:25
	269	<b>T70</b>

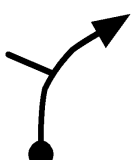
	2.15	
	V 30	
	270	<b>T70</b>

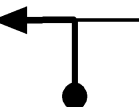
	2.22	
	V 30	
	271	<b>T70</b>

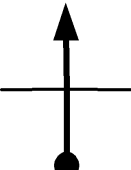
	2.62	
	V 30	
	272	<b>T70</b>

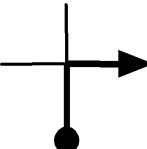
	2.63	
	V 30	
	273	<b>T70</b>



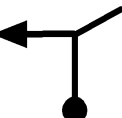

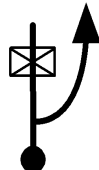
	2.72	
	V 30	
	274	<b>T70</b>

	3.61	
	V 30	
	275	<b>T70</b>

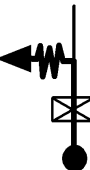
	3.76	
	V 30	
	276	<b>T70</b>

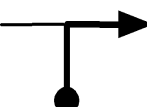
ENTRA NO CARREIRO

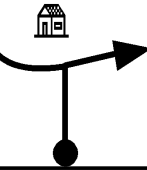
	3.78	
	V 39	02:38:39
	277	<b>T71</b>

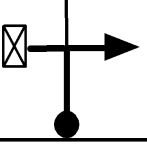
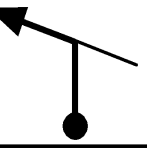
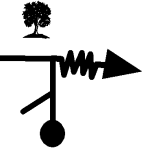
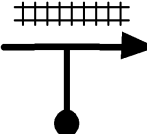
	4.36	
	V 39	
	278	<b>T71</b>
	4.39	
	0.00	
	V 39	02:39:36
	279	<b>T72</b>
	0.01	
	V 39	
	280	<b>T72</b>
	0.12	
	V 39	
	281	<b>T72</b>
	0.37	
	V 24	02:40:10
	282	<b>T73</b>
	0.45	
	V 24	
	283	<b>T73</b>
	0.48	
	V 24	
	284	<b>T73</b>
	0.79	
	V 24	
	285	<b>T73</b>

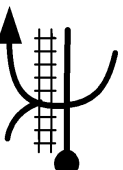
	0.89	
	V 24	
	286	T73

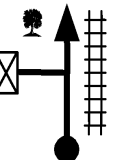
	1.15	
	V 24	
	287	T73

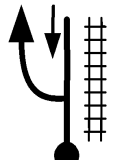
	1.34	
	V 24	
	288	T73

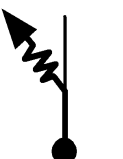
	1.41	
	V 27	02:42:46
	289	T74

Siga os BAMPS

	1.60	
	V 27	
	290	T74

Siga os BAMPS

	1.86	
	V 27	
	291	T74

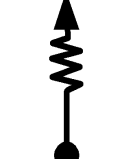
	1.92	
	V 27	
	292	T74

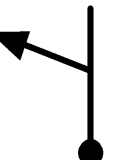
	2.16	
	V 27	
	293	T74

	2.40	
	V 21	02:44:58
	294	<b>T75</b>

	2.58	
	V 21	
	295	<b>T75</b>

	2.64	
	V 21	
	296	<b>T75</b>

	2.77	
	V 21	
	297	<b>T75</b>

	2.85	
	V 21	
	298	<b>T75</b>

CUIDADO

PENHASCO













	2.90	
	V 21	
	299	<b>T75</b>

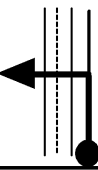

	3.02	
	V 21	
	300	<b>T75</b>



	3.09	
	V 24	02:46:56
	301	<b>T76</b>
	3.39	
	V 24	
	302	<b>T76</b>
	3.46	
	V 36	02:47:52
	303	<b>T77</b>
		
	4.10	
	D 5'	02:48:56
	304	<b>T78</b>
		
	4.50	
	305	<b>T78</b>
	4.68	
	306	<b>T78</b>
	5.62	
	307	<b>T78</b>
	5.76	
		02:53:56
	308	<b>T78</b>

**FIM DE PROVA !!**



[www.t15.com.br](http://www.t15.com.br)

**Tempo de Prova**

MÉDIA B 02:53:56

**FIM**