

**INICIO**

**MÉDIA C**

ENDURO TRILHEIROS DO RIO  
16 DE JUNHO DE 2018



**IMPORTANTE**

PLANILHA TERMICA  
FITA ADESIVA DO LADO DE  
TRÁS. NÃO USE CANETA  
MARCA TEXTO,  
USE CANETA ESFEROGRÁFICA

OU HIDROGRÁFICA

-----  
DIRETORES DE PROVA:  
SAMUEL  
GUSTAVO

REALIZAÇÃO:  
EQUIPE TRILHEIROS DO RIO

NOS TRECHOS URBANOS  
PREVALECEM AS LEIS DO  
CÓDIGO NACIONAL DE  
TRANSITO. É OBRIGAÇÃO  
RESPEITAR AS  
PROPRIEDADES  
ALHEIAS E OS MORADORES.  
A ORGANIZAÇÃO NÃO SE  
RESPONSABILIZA POR  
PASSAR  
PROGRAMAÇÃO DE  
NAVEGAÇÃO.  
É OBRIGAÇÃO DO PILOTO  
CONFERIR A PROGRAMAÇÃO  
DO  
NAVEGADOR.

LARGADA - 14:00 HS  
NEUTRO PRINCIPAL  
EMPRESA RIO TELAS  
CHEGADA NO MESMO  
LOCAL DA LARGADA

1 ETAPA KM 29,63  
2 ETAPA KM 32,68  
TOTAL KM 62,31

LEVANTAMENTO DA PROVA  
COM MOTO WR 250F COM  
PNEU DIANTEIRO BOM  
E 11 LIBRAS

☠	CUIDADO
☠☠	ATENÇÃO
☠☠☠	MUITA ATENÇÃO

## Tempo de Prova

MÉDIA C 02:55:42



## AFERIÇÃO

	0.00
	0.00
	1 AFER
	0.13
	2 AFER
	0.29
	3 AFER
	0.59
	4 AFER
	1.07
	5 AFER

	1.23
	0.00
	6 AFER



**INICIO DE PROVA**

	0.00
	V 24 00:00:00
	7 T1

	0.13
	V 39 00:00:20
	8 T2

	0.29
	V 39
	9 T2

	0.59
	V 39
	10 T2

	1.07
	V 39
	11 T2

	1.23	
	D 2'	00:02:01
	12	<b>T3</b>

FIM DESLOCAMENTO

	1.64	
	V 33	00:04:01
	13	<b>T4</b>

	2.32	
	V 33	
	14	<b>T4</b>

	2.35	
	V 33	
	15	<b>T4</b>

BAMP

	2.65	
	V 33	
	16	<b>T4</b>

BAMP

	2.83	
	V 33	
	17	<b>T4</b>

BAMP

	2.96	
	V 33	
	18	<b>T4</b>

	3.16
	V 24 00:06:47
	19 <b>T5</b>

Andar pelo trilho

	3.23
	V 24
	20 <b>T5</b>

	3.42
	V 24
	21 <b>T5</b>

	3.65
	V 24
	22 <b>T5</b>

	3.77
	V 18 00:08:18
	23 <b>T6</b>

	4.07
	V 18
	24 <b>T6</b>

	4.10
	V 18
	25 <b>T6</b>

	4.17
	V 36 00:09:38
	26 <b>T7</b>

	4.57	
	V 36	
	27	T7

	5.74	
	V 36	
	28	T7

	5.83	
	V 36	
	29	T7

	6.16	
	V 15	00:12:57
	30	<b>T8</b>

	6.35	
	V 15	
	31	T8

	6.44	
	V 15	
	32	T8

SOBE



	6.85	
	V 30	00:15:43
	33	<b>T9</b>

	7.77	
	V 30	
	34	T9

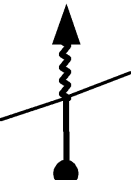
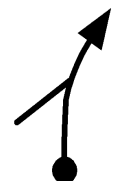
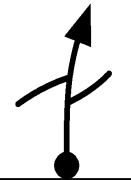
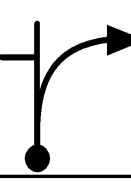
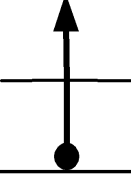
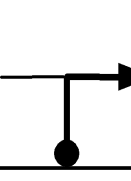
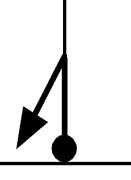
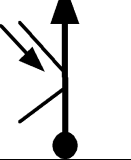
	7.91
	N 1' 00:17:50
	35 <b>T10</b>
	7.91
	V 30 00:18:50
	36 <b>T11</b>
	7.96
	0.00
	V 30 00:18:56
	0.18
	V 30
	38 <b>T12</b>
	0.31
	V 42 00:19:33
	39 <b>T13</b>
	0.76
	V 42
	40 <b>T13</b>
	1.28
	V 27 00:20:56
	41 <b>T14</b>
	1.48
	V 27
	42 <b>T14</b>

	1.70
	V 27
	43 T14
	1.87
	V 27
	44 T14
	1.93
	V 27
	45 T14
	2.01
	V 18 00:22:34
	46 T15
	2.05
	V 18
	47 T15
	2.09
	V 18
	48 T15
	2.12
	V 18
	49 T15
	2.18
	V 18
	50 T15

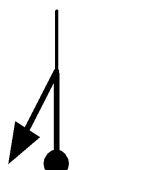
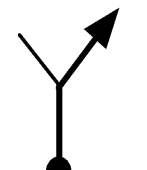
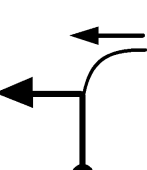
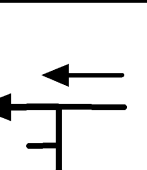

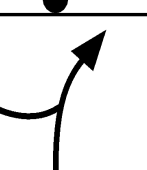
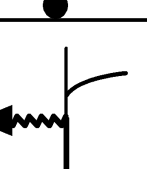
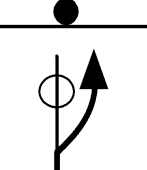
	2.26	
	V 18	
	51	T15
	2.28	
	V 18	
	52	T15
	2.31	
	V 18	
	53	T15
	2.40	
	V 18	
	54	T15
	2.46	
	V 18	
	55	T15
	2.72	
	V 18	
	56	T15
	2.98	
	V 15	00:25:48
	57	T16
	3.07	
	V 15	
	58	T16

	3.12	
	V 15	
	59	<b>T16</b>



	3.31	
	V 15	
	60	<b>T16</b>

	3.38	
	V 15	
	61	<b>T16</b>



	3.47	
	V 15	
	62	<b>T16</b>



	4.38	
	N 2'	00:31:24
	63	<b>T17</b>

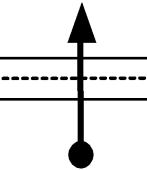
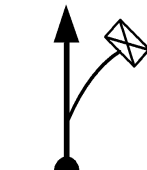

	4.38	
	V 24	00:33:24
	64	<b>T18</b>

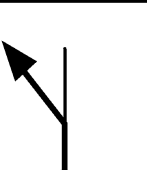
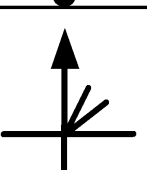
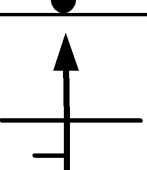
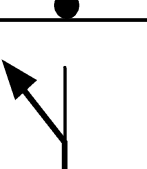
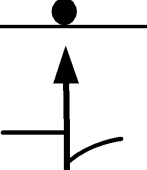
	4.55	
	V 24	
	65	<b>T18</b>

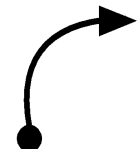
	4.69	
	V 24	
	66	<b>T18</b>
	4.80	
	V 27	00:34:27
	67	<b>T19</b>
	4.85	
	V 27	
	68	<b>T19</b>
	5.05	
	V 27	
	69	<b>T19</b>
	5.26	
	V 27	
	70	<b>T19</b>
	5.84	
	V 27	
	71	<b>T19</b>
	6.10	
	<b>0.00</b>	
	V 33	00:37:20
	72	<b>T20</b>
	0.52	
	N 1'	00:38:17
	73	<b>T21</b>

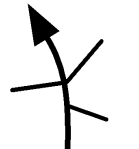
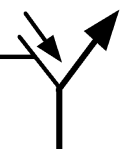
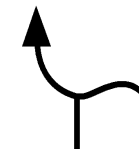
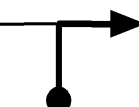
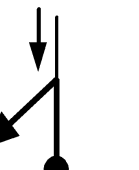
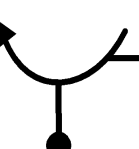
	0.52
	V 21 00:39:17
	74 <b>T22</b>
	1.69
	V 39 00:42:37
	75 <b>T23</b>
	1.93
	V 39
	76 <b>T23</b>
	2.08
	V 24 00:43:13
	77 <b>T24</b>
	2.41
	V 24
	78 <b>T24</b>
	2.47
	V 24
	79 <b>T24</b>
	2.50
	V 24
	80 <b>T24</b>
	2.81
	V 18 00:45:03
	81 <b>T25</b>

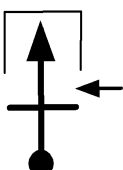
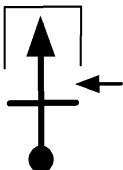
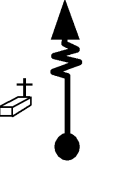
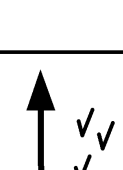
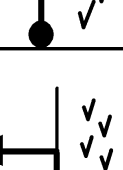
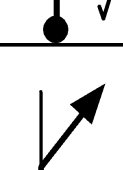
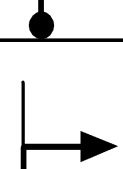
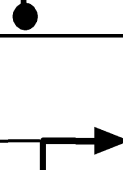
	3.49	
	V 18	
	82	T25
	3.52	
	V 18	
	83	T25
	4.38	
	V 18	
	84	T25
	4.57	
	V 18	
	85	T25
	4.65	
	V 18	
	86	T25
	4.67	
	V 18	
	87	T25
	4.78	
	V 18	
	88	T25
	4.91	
	V 18	
	89	T25

	5.02
	N 1' 00:52:25
	90 <b>T26</b>
	5.02
	V 15 00:53:25
	91 <b>T27</b>
	5.13
	0.00
	V 18 00:53:51
	92 <b>T28</b>
	0.69
	V 18
	93 <b>T28</b>
	0.77
	V 18
	94 <b>T28</b>
	0.83
	V 18
	95 <b>T28</b>
	1.51
	V 18
	96 <b>T28</b>
	1.56
	V 18
	97 <b>T28</b>

	1.70
	V 18
	98 T28
	1.94
	V 18
	99 T28
	2.28
	V 18
	100 T28
	2.44
	V 18
	101 T28
	2.46
	V 18
	102 T28
	2.70
	V 18
	103 T28
	2.86
	V 18
	104 T28
	3.19
	V 18
	105 T28

	3.35	
	V 18	
	106	<b>T28</b>
	3.40	
	V 18	
	107	<b>T28</b>
	3.47	
	V 18	
	108	<b>T28</b>
	3.57	
	V 18	
	109	<b>T28</b>
	3.59	
	V 18	
	110	<b>T28</b>
	3.68	
	V 18	
	111	<b>T28</b>
	3.76	
	V 18	
	112	<b>T28</b>
	3.77	
	V 18	
	113	<b>T28</b>



	3.79	
	V 18	
	114	<b>T28</b>

	3.88	
	V 18	
	115	<b>T28</b>

	3.93	
	V 18	
	116	<b>T28</b>

	3.95	
	V 18	
	117	<b>T28</b>









	3.98	
	V 18	
	118	<b>T28</b>

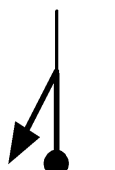

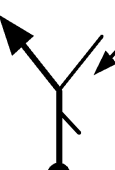

	4.14	
	V 18	
	119	<b>T28</b>





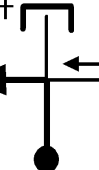

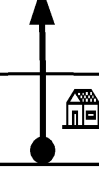

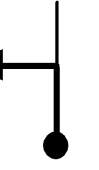

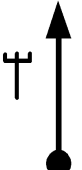
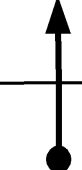
	4.18	
	V 18	
	120	<b>T28</b>

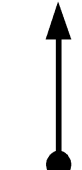
	4.44
	V 18
	121 T28
	4.49
	N 1' 01:08:49
	122 T29
	4.49
	0.00
	V 36 01:09:49
	0.13
	V 36
	124 T30
	0.30
	V 36
	125 T30
	0.77
	V 36
	126 T30
	1.68
	V 36
	127 T30
	2.15
	V 36
	128 T30

	2.35	
	V 24	01:13:44
	129	<b>T31</b>
	2.62	
	V 24	
	130	<b>T31</b>
	2.70	
	V 24	
	131	<b>T31</b>
	2.77	
	V 24	
	132	<b>T31</b>
	2.83	
	V 24	
	133	<b>T31</b>
	2.89	
	V 24	
	134	<b>T31</b>
	2.91	
	V 24	
	135	<b>T31</b>
	3.00	
	V 24	
	136	<b>T31</b>

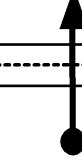
	3.03
	V 24
	137 T31
	3.15
	V 36 01:15:44
	138 T32
	4.27
	V 27 01:17:36
	139 T33
	4.98
	V 27
	140 T33
	5.18
	V 27
	141 T33
	5.79
	V 27
	142 T33
FIM 1ª ETAPA	
NEUTRO PRINCIPAL	
	5.95
	0.00
	N 14' 01:21:20
	143 T34

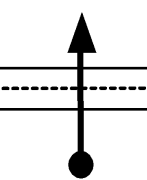
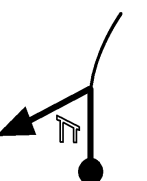
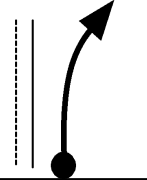
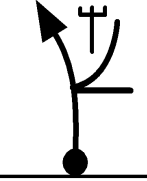
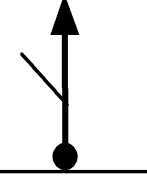
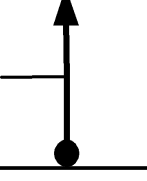
	0.00
	V 27 01:35:20
	144 <b>T35</b>
	0.31
	V 27
	145 <b>T35</b>
	0.57
	V 27
	146 <b>T35</b>
DESCE	
	0.79
	V 21 01:37:06
	147 <b>T36</b>
	0.82
	V 21
	148 <b>T36</b>
	1.08
	V 30 01:37:55
	149 <b>T37</b>
	1.31
	0.00
	V 18 01:38:23
	150 <b>T38</b>
	
	0.42
	N 1' 01:39:47
	151 <b>T39</b>

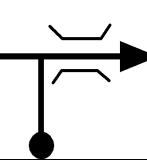
	0.42
	V 30 01:40:47
	152 T40
	0.55
	V 30
	153 T40
	0.76
	V 30
	154 T40
	1.41
	V 30
	155 T40
	1.56
	V 30
	156 T40
	1.80
	V 30
	157 T40
	1.86
	V 30
	158 T40
	2.24
	V 39 01:44:25
	159 T41

	2.36	
	V 39	
	160	<b>T41</b>
	3.08	
	V 39	
	161	<b>T41</b>
	3.27	
	V 39	
	162	<b>T41</b>
	3.51	
	0.00	
	V 21	01:46:23
	163	<b>T42</b>
	0.02	
	V 21	
	164	<b>T42</b>
	0.21	
	V 24	01:46:59
	165	<b>T43</b>
	0.39	
	V 24	
	166	<b>T43</b>
	0.50	
	V 24	
	167	<b>T43</b>

	0.91	
	V 24	
	168	<b>T43</b>
	1.01	
	V 24	
	169	<b>T43</b>
	1.18	
	V 24	
	170	<b>T43</b>
	1.23	
	N 1'	01:49:32
	171	<b>T44</b>
	1.23	
	V 30	01:50:32
	172	<b>T45</b>
	1.41	
	V 30	
	173	<b>T45</b>
	1.55	
	V 30	
	174	<b>T45</b>
	1.75	
	V 24	01:51:34
	175	<b>T46</b>



	1.93	
	V 24	
	176	<b>T46</b>

	2.04	
	V 24	
	177	<b>T46</b>

	2.45	
	V 24	
	178	<b>T46</b>

	2.65	
	V 24	
	179	<b>T46</b>



	2.68	
	V 24	
	180	<b>T46</b>

	2.81	
	V 24	
	181	<b>T46</b>

	2.92	
	V 24	
	182	<b>T46</b>

	3.05	
	V 24	
	183	<b>T46</b>

	3.18	
	V 24	
	184	<b>T46</b>

	3.29	
	V 24	
	185	<b>T46</b>

Siga os BAMPS

	3.72	
	V 24	
	186	<b>T46</b>

	3.77	
	V 24	
	187	<b>T46</b>

	3.81	
	N 1' 01:56:43	
	188	<b>T47</b>

	3.81	
	V 30 01:57:43	
	189	<b>T48</b>

COSTEAR BARRANCO

	3.90	
	V 30	
	190	<b>T48</b>

	4.07
	V 24 01:58:14
	191 <b>T49</b>
	4.24
	V 24
	192 <b>T49</b>
	4.30
	V 24
	193 <b>T49</b>
	4.54
	V 15 01:59:25
	194 <b>T50</b>
	4.63
	V 15
	195 <b>T50</b>
	4.94
	V 24 02:01:01
	196 <b>T51</b>
	4.97
	V 24
	197 <b>T51</b>
	5.24
	V 27 02:01:46
	198 <b>T52</b>

	5.60
	0.00
	V 36 02:02:34
199	<b>T53</b>
	0.03
	V 36
	200
	0.16
	V 36
	201
	0.44
	V 24 02:03:18
	202
	0.57
	V 24
	203
	0.67
	V 24
	204
	0.72
	V 24
	205
	0.75
	V 24
	206

	0.96	
	V 24	
	207	<b>T54</b>
	1.08	
	N 1'	02:04:54
	208	<b>T55</b>
	1.08	
	V 24	02:05:54
	209	<b>T56</b>
	1.11	
	V 27	02:05:58
	210	<b>T57</b>
	1.25	
	V 27	
	211	<b>T57</b>
	1.32	
	V 27	
	212	<b>T57</b>
	1.35	
	V 27	
	213	<b>T57</b>
	1.42	
	V 27	
	214	<b>T57</b>

	1.46
	V 27
	215 T57
	1.54
	V 27
	216 T57
	1.60
	V 27
	217 T57
	1.64
	V 21 02:07:09
	218 T58
	1.71
	V 21
	219 T58
	1.80
	V 21
	220 T58
	1.92
	V 21
	221 T58
	1.95
	V 21
	222 T58

	2.13	
	V 21	
	223	<b>T58</b>
	2.22	
	V 21	
	224	<b>T58</b>
	2.28	
	V 21	
	225	<b>T58</b>
	2.45	
	V 21	
	226	<b>T58</b>
	2.61	
	V 24	02:09:55
	227	<b>T59</b>
	2.63	
	V 24	
	228	<b>T59</b>
	2.66	
	V 24	
	229	<b>T59</b>
	2.77	
	V 24	
	230	<b>T59</b>

	2.82	
	V 24	
	231	<b>T59</b>
	2.86	
	V 24	
	232	<b>T59</b>
	3.04	
	V 24	
	233	<b>T59</b>
	3.10	
	V 21	02:11:09
	234	<b>T60</b>
	3.39	
	V 21	
	235	<b>T60</b>
	3.55	
	V 21	
	236	<b>T60</b>
	3.65	
	N 1'	02:12:43
	237	<b>T61</b>
	3.65	
	V 27	02:13:43
	238	<b>T62</b>

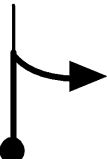

	3.82	
	V 33	02:14:06
	239	<b>T63</b>

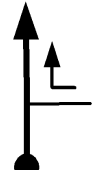

	3.90	
	V 33	
	240	<b>T63</b>

	4.28	
	V 33	
	241	<b>T63</b>

	4.47	
	V 33	
	242	<b>T63</b>

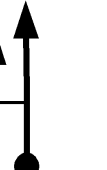
	4.67	
	V 33	
	243	<b>T63</b>

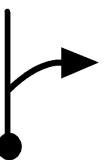
	4.83	
	V 33	
	244	<b>T63</b>

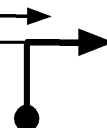

	5.00	
	V 33	
	245	<b>T63</b>

	5.38	
	V 33	
	246	<b>T63</b>
	5.56	
	V 33	
	247	<b>T63</b>
	5.71	
	V 33	
	248	<b>T63</b>
	5.89	
	V 33	
	249	<b>T63</b>
	5.94	
	V 21	02:17:57
	250	<b>T64</b>
	6.04	
	V 21	
	251	<b>T64</b>
	6.57	
	V 21	
	252	<b>T64</b>
	6.61	
	V 21	
	253	<b>T64</b>

	6.70	
	V 21	
	254	<b>T64</b>
	6.73	
	V 21	
	255	<b>T64</b>
	6.83	
	V 21	
	256	<b>T64</b>
	6.98	
	V 21	
	257	<b>T64</b>
	7.21	
	0.00	
	N 1'	02:21:35
	258	<b>T65</b>
	0.00	
	V 30	02:22:35
	259	<b>T66</b>
	0.34	
	V 30	
	260	<b>T66</b>
	0.59	
	V 30	
	261	<b>T66</b>

	0.89
	V 30
	262 <b>T66</b>
	1.17
	V 30
	263 <b>T66</b>
	1.91
	V 42 02:26:24
	264 <b>T67</b>
	4.10
	V 42
	265 <b>T67</b>
	4.90
	0.00
	V 42 02:30:40
	0.77
	V 15 02:31:46
	267 <b>T69</b>
	1.11
	V 15
	268 <b>T69</b>
	1.16
	V 27 02:33:20
	269 <b>T70</b>

	2.15	
	V 27	
	270	T70

	2.22	
	V 27	
	271	T70

	2.62	
	V 27	
	272	T70

	2.63	
	V 27	
	273	T70

	2.72	
	V 27	
	274	T70

	3.61	
	V 27	
	275	T70

	3.76	
	V 27	
	276	T70

ENTRA NO CARREIRO

	3.78	
	V 36	02:39:09
	277	T71

	4.36	
	V 36	
	278	T71
	4.39	
	0.00	
	V 39	02:40:10
	0.01	
	V 39	
	280	T72
	0.12	
	V 39	
	281	T72
	0.37	
	V 21	02:40:44
	282	T73
	0.45	
	V 21	
	283	T73
	0.48	
	V 21	
	284	T73
	0.79	
	V 21	
	285	T73

	0.89	
	V 21	
	286	<b>T73</b>

	1.15	
	V 21	
	287	<b>T73</b>

	1.34	
	V 21	
	288	<b>T73</b>

	1.41	
	V 24	02:43:42
	289	<b>T74</b>

Siga os BAMPS

	1.60	
	V 24	
	290	<b>T74</b>

Siga os BAMPS

	1.86	
	V 24	
	291	<b>T74</b>

	1.92	
	V 24	
	292	<b>T74</b>

	2.16	
	V 24	
	293	<b>T74</b>

	2.40	
	V 18	02:46:11
	294	<b>T75</b>

	2.58	
	V 18	
	295	<b>T75</b>

	2.64	
	V 18	
	296	<b>T75</b>

	2.77	
	V 18	
	297	<b>T75</b>

	2.85	
	V 18	
	298	<b>T75</b>

CUIDADO

PENHASCO













	2.90	
	V 18	
	299	<b>T75</b>

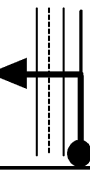

	3.02	
	V 18	
	300	<b>T75</b>



	3.09	
	V 21	02:48:29
	301	<b>T76</b>
	3.39	
	V 21	
	302	<b>T76</b>
	3.46	
	V 33	02:49:32
	303	<b>T77</b>
		
	4.10	
	D 5'	02:50:42
	304	<b>T78</b>
		
	4.50	
	305	<b>T78</b>
	4.68	
	306	<b>T78</b>
	5.62	
	307	<b>T78</b>
	5.76	
		02:55:42
	308	<b>T78</b>

**FIM DE PROVA !!**



[www.t15.com.br](http://www.t15.com.br)

**Tempo de Prova**

MÉDIA C 02:55:42

**FIM**