

INICIO

MÉDIA B

6ª ETAPA COPA MTC
21/10/2017 RINCAO



IMPORTANTE

**DIRETOR DE PROVA
FABRÍCIO MEDEIROS
(CABRITO)**

Nos trechos urbanos
prevalecem as leis do
código nacional de
trânsito.



É obrigação respeitar as
propriedades alheias e
os moradores.

A organização não se
responsabiliza por
passar a programação de
navegação.

Conferir sequências
numéricas das tulipas
Onde não a referência
mantenha-se na
principal.

**LEVANTAMENTO DA PROVA
MOTO SHERCO COM PNEU
NOVO 10 LIBRAS**

**BOA SORTE A
TODOS!!!!!!!!!!!!!!!!!!!!!!
!!!!!!!!!!!!**

	CUIDADO
	ATENÇÃO
	MUITA ATENÇÃO

Tempo de Prova

MÉDIA B 03:02:28



AFERIÇÃO

INICIO DA AFERIÇÃO



	0.00		
		1	AFER
	0.03		
		2	AFER
	0.14		
		3	AFER
	0.45		
		4	AFER
	0.66		
		5	AFER
	1.22		
		6	AFER

	1.60	
	7	A FER

RETORNAR AO INICIO

	1.84	
	8	A FER



INICIO DE PROVA

INICIO DA PROVA.

	0.00	
	V 36	00.00.00
	9	T1

	0.03	
	V 36	
	10	T1

	0.14	
	V 36	
	11	T1

	0.45	
	V 36	
	12	T1

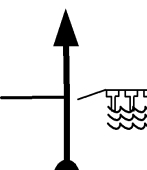
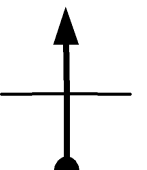
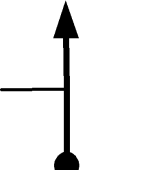
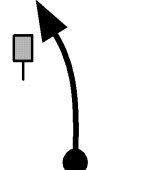
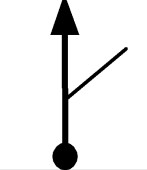
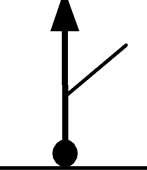
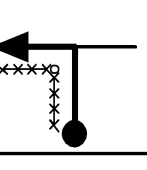
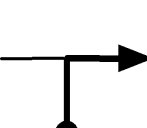
	<p>0.66</p> <p>V 36</p> <p>13 T1</p>
	<p>1.22</p> <p>V 36</p> <p>14 T1</p>
	<p>1.60</p> <p>V 36</p> <p>15 T1</p>
	<p>1.84</p> <p>V 36</p> <p>16 T1</p>
	<p>2.04</p> <p>V 36</p> <p>17 T1</p>
	<p>2.39</p> <p>V 36</p> <p>18 T1</p>
	<p>2.66</p> <p>V 42 00.04.26</p> <p>19 T2</p>
	<p>3.27</p> <p>V 42</p> <p>20 T2</p>

	5.21	
	V 42	
	21	T2
	5.46	
	V 42	
	22	T2
	5.64	
	V 36	00.08.41
	23	T3
	5.71	
	V 36	
	24	T3
	6.01	
	V 36	
	25	T3
	6.14	
	V 36	
	26	T3
	6.18	
	V 36	
	27	T3
	6.53	
	N1'30s	00.10.10
	28	T4

	6.53	
	V 33	00.11.40
	29	T5
	6.72	
	V 45	00.12.01
	30	T6
	7.11	
	V 45	
	31	T6
	7.23	
	V 45	
	32	T6
	7.53	
	V 45	
	33	T6
	7.63	
	V 45	
	34	T6
	8.01	
	V 45	
	35	T6
	8.34	
	V 45	
	36	T6

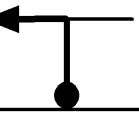
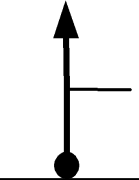
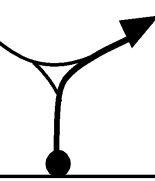
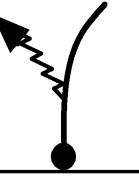
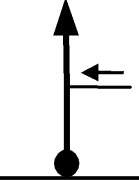
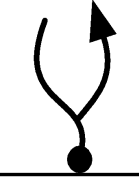
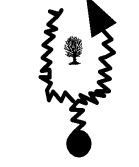
	8.36	
	N 1'	00.14.12
	37	T7
	8.36	
	V 36	00.15.12
	38	T8
	8.59	
	V 36	
	39	T8
	8.72	
	V 36	
	40	T8
	8.75	
	V 36	
	41	T8
	8.98	
	V 36	
	42	T8
	9.12	
	V 36	
	43	T8
	9.14	
	V 36	
	44	T8

	9.15
	V 36
	45 T8

	9.50
	N 1' 00.17.06
	46 T9

	9.50
	0.00
	V 36 00.18.06
47	T10

	0.18
	V 36
	48 T10

	0.64
	V 36
	49 T10

CAIXA DE AGUA

	0.89
	V 36
	50 T10

	1.14
	V 36
	51 T10

	1.28
	V 33 00.20.14
	52 T11

	1.41	
	V 33	
	53	T11

	1.55	
	V 33	
	54	T11

	1.84	
	V 33	00.21.15
	55	T12

	2.11	
	V 33	
	56	T12

	2.17	
	V 33	
	57	T12

VALO







	2.31	
	V 33	
	58	T12

VALO

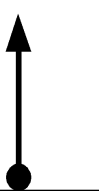
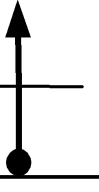
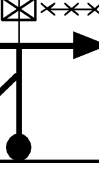
	2.38	
	V 33	
	59	T12

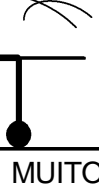

	2.66	
	V 33	
	60	T12

ATOLEIRO	
	2.74
	V 33
	61 T12
	2.79
	V 33
	62 T12
	2.93
	V 30 00.23.14
	63 T13
SIGA BAMP	
	3.08
	V 30
	64 T13
	3.12
	V 30
	65 T13
	3.16
	V 30
	66 T13
	3.23
	V 30
	67 T13
MUITO CUIDADO	
	
	3.28
	V 45 00.23.56
	68 T14

EM DIREÇÃO A CASA

	4.00
	V 39 00.24.54
	69 T15

	4.07
	V 39
	70 T15

	4.09
	V 39
	71 T15

	4.70
	V 39
	72 T15

	4.87
	V 39
	73 T15

	4.91
	V 39
	74 T15

	4.95
	V 39
	75 T15

	5.29
	V 39
	76 T15

	5.40	
	V 39	
	77	T15

CONTORNE A AGUA

	5.44	
	V 39	
	78	T15

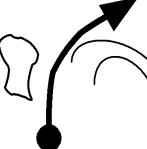
	5.53	
	V 39	
	79	T15

	5.71	
	N1'30	00.27.32
	80	T16

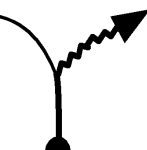
	5.71	
	V 36	00.29.02
	81	T17

	5.84	
	V 36	
	82	T17

BAMP

	6.00	
	V 36	
	83	T17

	6.14	
	V 36	
	84	T17

	6.23	
	V 36	
	85	T17

	6.42	
	V 36	
	86	T17

	6.45	
	V 36	
	87	T17

	6.59	
	V 36	
	88	T17

	6.80	
	V 36	
	89	T17

	7.07	
	V 36	
	90	T17

	7.34	
	V 36	
	91	T17

LAJOTA

	7.75	
	V 36	
	92	T17

	7.90	
	V 36	
	93	T17

LAGOA

	8.33	
	V 36	
	94	T17

	9.23	
	V 36	
	95	T17

	9.95	
	V 36	
	96	T17

ATENÇÃO

<p>INICIO DESLOCAMENTO</p>		
----------------------------	--	--

	11.36	
	D1'30	00.38.27
	97	T18

FIM DESLOCAMENTO

	11.50	
	0.00	
	V 27	00.39.57
98	T19	

	0.12	
	V 27	
	99	T19

	0.24
	V 45 00.40.29
	100 T20
	0.30
	V 45
	101 T20
	0.37
	V 45
	102 T20
	0.45
	V 45
	103 T20
	0.62
	V 45
	104 T20
	0.76
	V 45
	105 T20
	0.92
	V 45
	106 T20
	0.98
	V 45
	107 T20

	1.06	
	V 45	
	108	T20

	1.23	
	V 45	
	109	T20

	1.26	
	V 45	
	110	T20

	1.41	
	V 45	
	111	T20

VALO

	1.66	
	V 45	
	112	T20

ATENÇÃO

INICIO DESLOCAMENTO

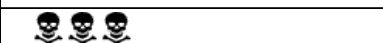

	1.96	
	D 2'	00.42.46
	113	T21

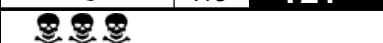





	2.90	
	114	T21

ATENÇÃO

FIM DESLOCAMENTO

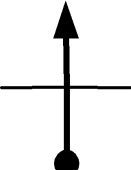
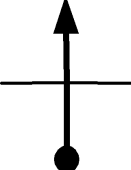
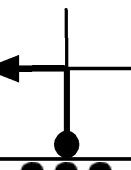

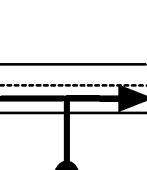
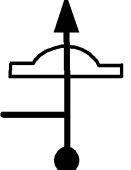
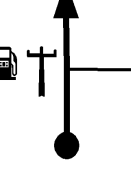
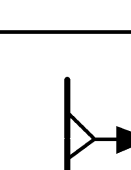
	3.04
	V 39 00.44.46
	115 T22
	3.24
	V 39
	116 T22
	3.26
	V 39
	117 T22
	3.32
	V 39
	118 T22
	3.46
	V 39
	119 T22
	3.63
	V 39
	120 T22

	3.79
	V 39
	121 T22
	3.97
	V 39
	122 T22
	4.13
	V 39
	123 T22
	
	4.22
	V 30 00.46.35
	124 T23
	4.36
	V 30
	125 T23
	4.92
	0.00
	V 30 00.47.59
	0.23
	V 30
	127 T24
FIM ASFALTO	
	0.53
	V 30
	128 T24

	1.60
	N 1' 00.51.11
	129 T25

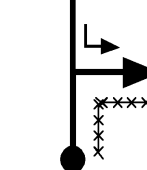
	1.60
	V 48 00.52.11
	130 T26

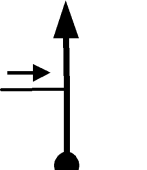
	2.29
	V 48
	131 T26

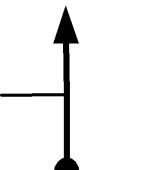
	2.64
	V 48
	132 T26

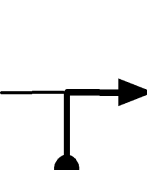

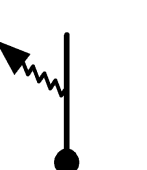
	3.29
	V 45 00.54.18
	133 T27

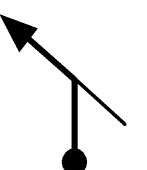
	3.33
	V 45
	134 T27

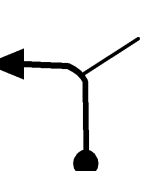
	3.37
	V 45
	135 T27

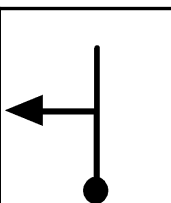
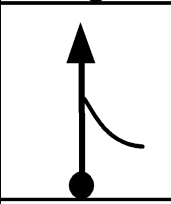
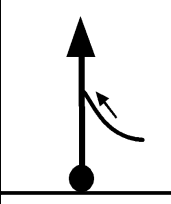
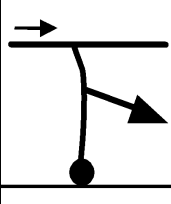
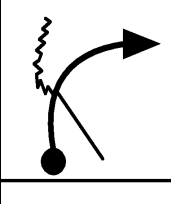
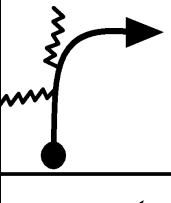
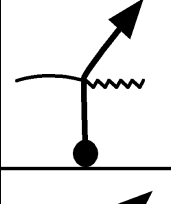
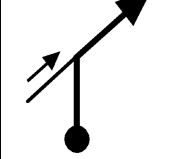
	3.64
	V 45
	136 T27

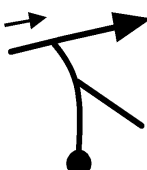
	3.74	
	V 45	
	137	T27
	3.81	
	V 45	
	138	T27
	3.87	
	V 45	
	139	T27
	4.02	
	V 45	
	140	T27
	4.16	
	V 45	
	141	T27
	4.25	
	V 45	
	142	T27
	4.36	
	V 45	
	143	T27
	4.46	
	V 45	
	144	T27

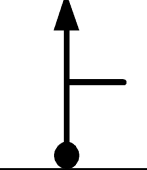
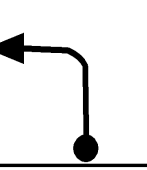
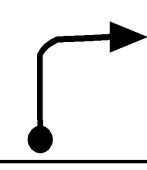
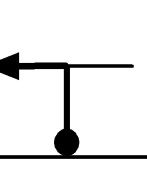
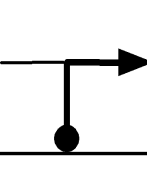
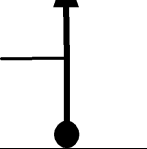
	4.61	
	V 45	
	145	T27
	4.63	
	V 45	
	146	T27
	4.84	
	V 45	
	147	T27
	5.25	
	V 45	
	148	T27
	5.27	
	V 45	
	149	T27
	5.49	
	V 45	
	150	T27
	5.60	
	V 45	
	151	T27
	5.63	
	V 45	
	152	T27

	5.85	
	V 45	
	153	T27
	5.95	
	V 45	
	154	T27
	6.00	
	V 45	
	155	T27
	6.05	
	V 48	00.57.59
	156	T28
	6.41	
	V 48	
	157	T28
	7.11	
	V 45	00.59.18
	158	T29
	7.14	
	V 45	
	159	T29
	7.16	
	V 45	
	160	T29

	7.38	
	V 45	
	161	T29

	7.45	
	V 45	
	162	T29

	7.57	
	V 45	
	163	T29

	8.07	
	V 45	
	164	T29

	8.27	
	V 45	
	165	T29

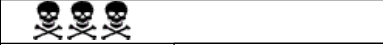

	9.04	
	N 3'	01.01.53
	166	T30



	9.04	
	0.00	
	V 48	01.04.53
	167	T31

	0.30	
	V 48	
	168	T31
	0.95	
	V 48	
	169	T31
	2.00	
	V 48	
	170	T31
	2.05	
	V 30	01.07.26
	171	T32
	2.48	
	V 30	
	172	T32
	2.98	
	N 1'	01.09.18
	173	T33
	2.98	
	V 27	01.10.18
	174	T34
	3.10	
	V 27	
	175	T34

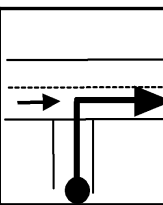
	3.22
V 27	
176	T34

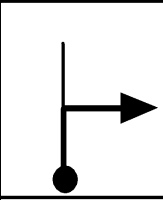
	3.42
V 36	01.11.17
177	T35

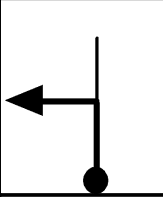
	3.45
V 36	
178	T35

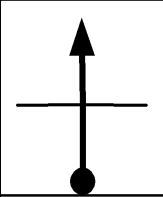
	3.61
V 36	
179	T35

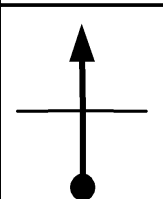

	4.10
V 36	
180	T35

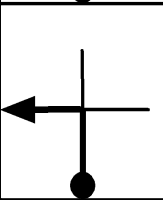
	4.26
V 36	
181	T35

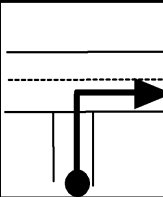
	4.30
V 27	01.12.45
182	T36

	4.43
	V 27
	183 T36

	5.00
	N 20' 01.14.18
	184 T37

APOIO

OLHO D'AGUA

	5.00
	0.00
	V 42 01.34.18
	185 T38

	0.56
	V 42
	186 T38

	1.06
	V 42
	187 T38

	1.94
	V 42
	188 T38

	2.12
	V 42
	189 T38

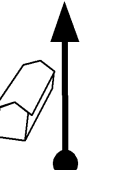
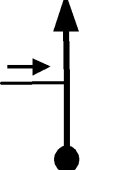
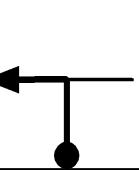
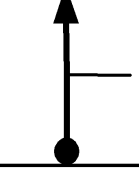
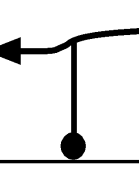
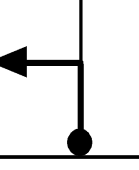
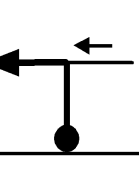
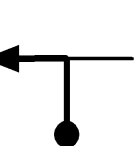
	2.30	
	V 45	01.37.35
	190	T39
	2.68	
	V 45	
	191	T39
	3.00	
	V 45	
	192	T39
	3.03	
	V 45	
	193	T39
	3.16	
	V 45	
	194	T39
	3.49	
	V 45	
	195	T39
	3.66	
	V 45	
	196	T39
	3.98	
	V 45	
	197	T39

	4.01	
	V 45	
	198	T39

	4.14	
	V 45	
	199	T39

	4.44	
	V 42	01.40.26
	200	T40

	4.47	
	V 42	
	201	T40

	4.50	
	V 36	01.40.32
	202	T41

	5.55	
	V 36	
	203	T41





	5.65	
	N 2'	01.42.27
	204	T42

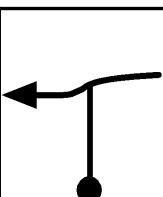
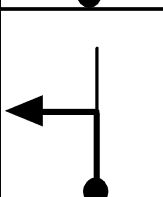
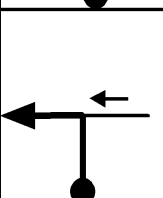
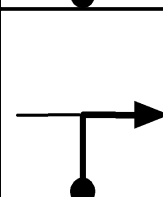
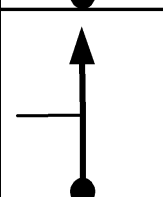
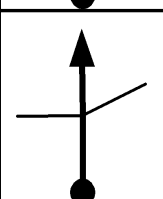
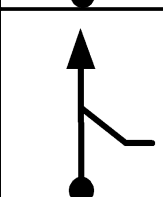
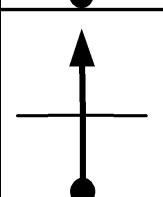

	5.65	
	V 36	01.44.27
	205	T43

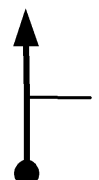
	5.72	
	V 36	
	206	T43
	5.79	
	V 36	
	207	T43
	6.53	
	V 36	
	208	T43
	6.64	
	V 42	01.46.06
	209	T44
	7.05	
	V 42	
	210	T44
	7.09	
	V 42	
	211	T44
	7.15	
	V 42	
	212	T44
	7.44	
	V 45	01.47.14
	213	T45

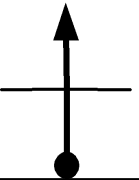
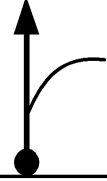
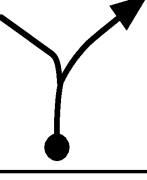
	7.56	
	V 45	
	214	T45
	7.89	
	V 45	
	215	T45
	8.06	
	V 45	
	216	T45
	8.38	
	V 42	01.48.29
	217	T46
	8.40	
	V 42	
	218	T46
	8.49	
	V 42	
	219	T46
	8.52	
	V 42	
	220	T46
	8.68	
	V 42	
	221	T46

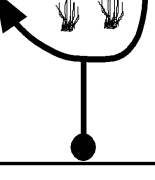
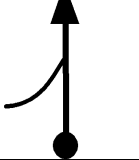
	8.84	
	V 42	
	222	T46
	8.98	
	N 1'	01.49.21
	223	T47
	8.98	
	V 42	01.50.21
	224	T48
	9.24	
	V 42	
	225	T48
	9.29	
	V 42	
	226	T48
	9.45	
	V 42	
	227	T48
	9.51	
	V 42	
	228	T48
	9.56	
	V 42	
	229	T48

	9.59	
	V 42	
	230	T48
	9.64	
	V 45	01.51.17
	231	T49
	9.81	
	V 45	
	232	T49
	10.01	
	V 45	
	233	T49
	10.15	
	V 45	01.51.58
	234	T50
	10.70	
	V 45	
	235	T50
	10.81	
	V 45	
	236	T50
	10.99	
	V 45	
	237	T50

	11.07	
	V 45	
	238	T50

	11.13	
	V 45	
	239	T50



	11.50	
	N 2'	01.53.46
	240	T51

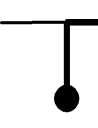

	11.50	
	0.00	
	V 42	01.55.46
	241	T52

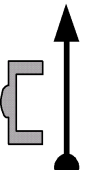
	0.94	
	V 42	
	242	T52

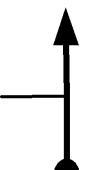
	1.79	
	V 42	
	243	T52

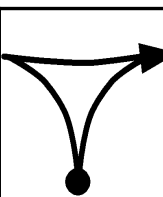
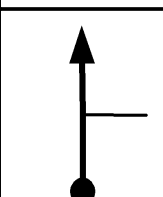
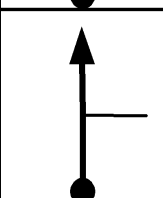
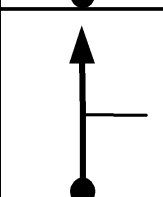
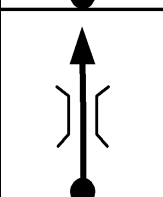
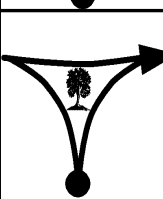
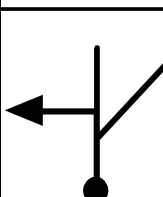
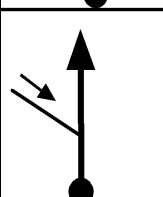
	2.60	
	V 42	
	244	T52
	2.97	
	V 42	
	245	T52
	3.11	
	V 42	
	246	T52
	4.25	
	V 42	
	247	T52
	4.38	
	V 42	
	248	T52
	4.75	
	V 42	
	249	T52
	4.87	
	V 39	02.02.44
	250	T53
	4.99	
	V 39	
	251	T53

MOTO CONTRA



	5.14	
	V 39	
	252	T53

	5.23	
	V 39	
	253	T53

	5.61	
	V 24	02.03.52
	254	T54

MOTO CONTRA



	5.70	
	V 39	02.04.05
	255	T55

MOTO CONTRA



	6.05	
	V 39	
	256	T55

	6.15	
	V 39	
	257	T55

	6.17	
	V 39	
	258	T55

	6.29	
	V 39	
	259	T55
	6.31	
	V 21	02.05.02
	260	T56
	6.33	
	V 21	
	261	T56
	6.36	
	V 27	02.05.10
	262	T57
	6.40	
	V 27	
	263	T57
	6.51	
	V 36	02.05.30
	264	T58
	6.55	
	V 36	
	265	T58
	6.59	
	V 36	
	266	T58

	6.68	
	V 36	
	267	T58

SIGA BAMP

	6.72	
	V 36	
	268	T58

	6.81	
	V 39	02.06.00
	269	T59



	6.94	
	V 39	
	270	T59

	7.03	
	V 39	
	271	T59

	7.06	
	V 39	
	272	T59

	7.18	
	V 33	02.06.34
	273	T60

	7.20	
	V 33	
	274	T60

	7.27	
	V 33	
	275	T60
	7.29	
	V 33	
	276	T60
	7.34	
	V 33	
	277	T60
	7.43	
	V 33	
	278	T60
	7.48	
	V 33	
	279	T60
	7.50	
	V 21	02.07.09
	280	T61
	7.53	
	V 21	
	281	T61
	7.55	
	V 21	
	282	T61

DESCE BARRANCO

	7.56
	V 27 02.07.20
	283 T62
	7.59
	V 27
	284 T62
	7.70
	V 36 02.07.38
	285 T63
	7.74
	V 36
	286 T63
	7.83
	V 36
	287 T63
	7.94
	V 36
	288 T63
	8.06
	V 45 02.08.14
	289 T64
	8.67
	V 21 02.09.03
	290 T65

	8.77	
	V 36	02.09.20
	291	T66

	9.12	
	V 36	
	292	T66

	9.21	
	V 36	
	293	T66

	9.23	
	V 36	
	294	T66

	9.35	
	V 36	
	295	T66

	9.37	
	V 21	02.10.20
	296	T67

	9.41	
	V 21	
	297	T67

	9.42	
	V 27	02.10.29
	298	T68

	9.46	
	V 27	
	299	T68



	9.57	
	V 36	02.10.49
	300	T69

	9.61	
	V 36	
	301	T69



	9.70	
	V 30	02.11.02
	302	T70

	9.92	
	V 30	
	303	T70

	9.96	
	V 30	
	304	T70

	10.00	
	V 30	
	305	T70

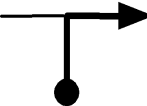
	10.07	
	V 30	
	306	T70
	10.20	
	V 30	
	307	T70
	10.22	
	V 21	02.12.04
	308	T71
	10.24	
	V 21	
	309	T71
	10.26	
	V 27	02.12.11
	310	T72
	10.28	
	V 27	
	311	T72
	10.31	
	V 27	
	312	T72
	10.42	
	V 36	02.12.32
	313	T73

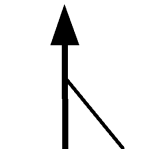
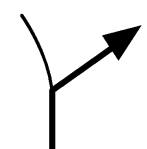
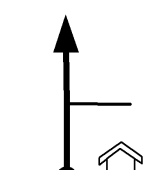
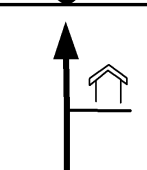
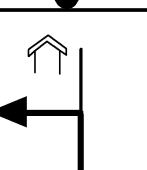
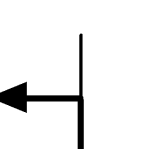
☠☠☠	
	<p>10.46</p> <p>0.00</p> <p>V 39 02.12.36</p> <p>314 T74</p>
	<p>0.09</p> <p>N3'30 02.12.45</p> <p>315 T75</p>
	<p>0.09</p> <p>V 39 02.16.15</p> <p>316 T76</p>
	<p>0.68</p> <p>V 42 02.17.09</p> <p>317 T77</p>
	<p>1.81</p> <p>V 42</p> <p>318 T77</p>
	<p>2.41</p> <p>V 42</p> <p>319 T77</p>
	<p>3.83</p> <p>V 42</p> <p>320 T77</p>
	<p>4.32</p> <p>V 36 02.22.21</p> <p>321 T78</p>

ATENÇÃO

MOTO CONTRA



	5.14
	V 27 02.23.43
	322 T79

	5.24
	V 27
	323 T79

	5.29
	V 27
	324 T79

	5.39
	V 18 02.24.16
	325 T80

	5.44
	V 18
	326 T80

	5.54
	V 24 02.24.46
	327 T81

MOTO CONTRA



	5.70
	V 21 02.25.10
	328 T82

	5.85	
	V 15	02.25.36
	329	T83

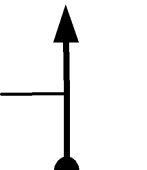
	5.94	
	V 15	
	330	T83

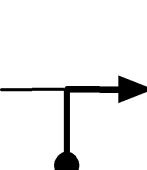
	6.00	
	V 15	
	331	T83

CUIDADO!

VALO

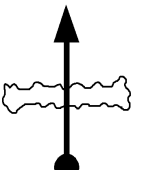
	6.05	
	V 21	02.26.24
	332	T84

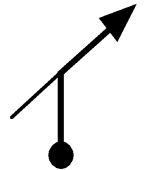
	6.09	
	V 21	
	333	T84

MOURÃO

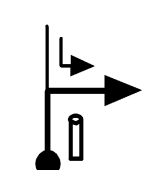

	6.15	
	V 21	
	334	T84

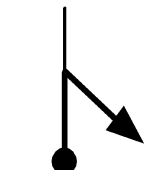
	6.29	
	V 15	02.27.05
	335	T85

	6.38	
	V 18	02.27.27
	336	T86
	6.42	
	V 18	
	337	T86
	7.52	
	V 18	
	338	T86
	7.71	
	V 27	02.31.53
	339	T87
	7.75	
	V 27	
	340	T87
	7.79	
	N3'30	02.32.03
	341	T88
	7.79	
	V 27	02.35.33
	342	T89
	7.94	
	V 27	
	343	T89

	8.03	
	V 27	
	344	T89
	8.08	
	V 36	02.36.12
	345	T90
	8.16	
	V 36	
	346	T90
	8.31	
	V 36	
	347	T90
	8.38	
	V 30	02.36.42
	348	T91
	9.12	
	V 36	02.38.11
	349	T92
	9.20	
	V 36	
	350	T92
	9.46	
	V 36	
	351	T92

	9.60	
	V 30	02.38.59
	352	T93

	9.87	
	V 36	02.39.31
	353	T94

CUIDADO!

ABISMO



	10.06	
	V 36	
	354	T94

	10.09	
	V 36	
	355	T94

	10.40	
	V 36	
	356	T94

	10.81	
	V 36	
	357	T94

CUIDADO!

ABISMO

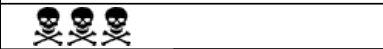

	11.00	
	V 36	
	358	T94

	11.03	
	V 36	
	359	T94

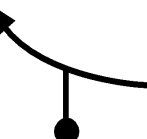

	11.34	
	N1'30s	02.41.58
	360	T95

	11.34	
	V 39	02.43.28
	361	T96

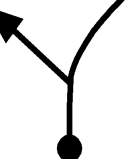



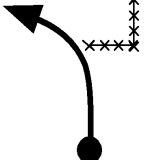

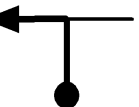
	11.36	
	V 39	
	362	T96

	11.50	
	V 39	
	363	T96

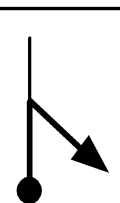
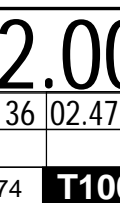
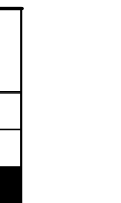





	11.67	
	V 39	
	364	T96

	11.75	
	0.00	
	V 33	02.44.06
365	T97	

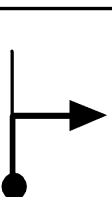
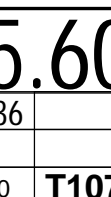
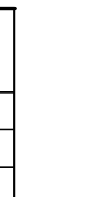

	0.22
	V 15 02.44.30
	366 T98
	0.31
	V 42 02.44.52
	367 T99
	0.52
	V 42
	368 T99
	0.86
	V 42
	369 T99
	0.91
	V 42
	370 T99
	1.39
	V 42
	371 T99
	1.61
	V 42
	372 T99
	1.95
	V 42
	373 T99

	2.00
	V 36 02.47.17
	374 T100
	2.06
	V 36
	375 T100
	2.23
	V 36
	376 T100
	2.26
	V 36
	377 T100
	2.72
	N 1' 02.48.29
	378 T101
	2.72
	V 39 02.49.29
	379 T102
	3.17
	V 39
	380 T102
	3.26
	V 27 02.50.18
	381 T103

	3.40
	V 27
	382 T103
	3.54
	V 27
	383 T103
	3.62
	V 45 02.51.06
	384 T104
	4.55
	V 48 02.52.21
	385 T105
	5.16
	V 48
	386 T105
	5.35
	N 1' 02.53.21
	387 T106
	5.35
	V 36 02.54.21
	388 T107
	5.47
	V 36
	389 T107

	5.60
	V 36
	390 T107
	5.70
	V 36
	391 T107
	5.85
	V 36
	392 T107
	6.03
	V 42 02.55.29
	393 T108
	6.08
	V 42
	394 T108
	6.17
	V 42
	395 T108
	6.36
	V 42
	396 T108
	6.50
	V 42
	397 T108

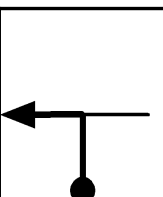
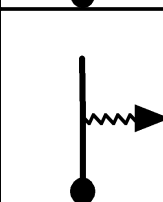
	6.70	
	V 42	
	398	T108
	6.87	
	V 42	
	399	T108
	7.30	
	V 42	
	400	T108
	7.37	
	N1'30	02.57.24
	401	T109
	7.37	
	V 33	02.58.54
	402	T110
	7.46	
	V 33	
	403	T110
	7.64	
	V 33	
	404	T110
	7.73	
	V 33	
	405	T110

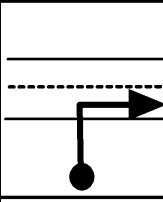
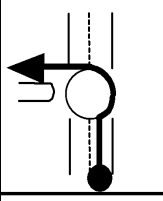
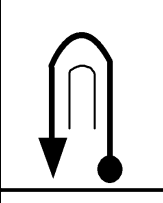
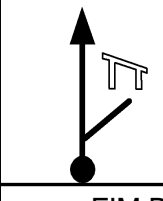
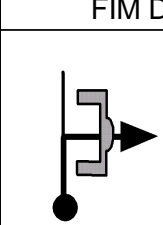
	7.93	
	V 33	
	406	T110
	7.95	
	V 33	
	407	T110
	8.16	
	N 1'	03.00.20
	408	T111
	8.16	
	V 27	03.01.20
	409	T112
	8.30	
	V 27	
	410	T112
	8.54	
	V 27	
	411	T112
	8.64	
	V 27	
	412	T112
FIM DE PROVA		
	8.67	
	V 27	03.02.28
	413	T112

FIM DE PROVA !!



www.t15.com.br

Obrigado pela sua
participação

Ate a proxima

Tenha uma boa viagem de
volta para sua casa!!!

Tempo de Prova

MÉDIA B 03:02:28

FIM